



A MITEL
PRODUCT
GUIDE

OpenScape DECT Phone SL7 on Cordless Enterprise

User Guide
04/2026

Notices

The information contained in this document is believed to be accurate in all respects but is not warranted by Mitel Europe Limited. The information is subject to change without notice and should not be construed in any way as a commitment by Mitel or any of its affiliates or subsidiaries. Mitel and its affiliates and subsidiaries assume no responsibility for any errors or omissions in this document. Revisions of this document or new editions of it may be issued to incorporate such changes. No part of this document can be reproduced or transmitted in any form or by any means - electronic or mechanical - for any purpose without written permission from Mitel Networks Corporation.

Trademarks

The trademarks, service marks, logos, and graphics (collectively “Trademarks”) appearing on Mitel’s Internet sites or in its publications are registered and unregistered trademarks of Mitel Networks Corporation (MNC) or its subsidiaries (collectively “Mitel”), Unify Software and Solutions GmbH & Co. KG or its affiliates (collectively “Unify”) or others. Use of the Trademarks is prohibited without the express consent from Mitel and/or Unify. Please contact our legal department at iplegal@mitel.com for additional information. For a list of the worldwide Mitel and Unify registered trademarks, please refer to the website: <http://www.mitel.com/trademarks>.

© Copyright 2026, Mitel Networks Corporation

All rights reserved

Contents

Overview	6
Handset	6
Illustration in the user guide	7
Safety precautions	8
Getting started	10
Contents of the package	10
Handset	10
Using the telephone	14
Getting to know your telephone	14
Making calls	18
Call lists	21
Message lists	22
Directories	23
Answering machine	28
Additional functions	29
Sound profiles	29
Calendar	30
Timer	32
Alarm clock	32
Protection against unwanted calls	33
Resource Directory	35
Bluetooth	36
Adjusting the telephone settings	39
Appendix	48
Manufacturer's advice	48
Technical data	50
Display icons	54
Accessing system functions	58
Making calls to multiple parties	59
Consultation	59
Caller list	69
Central directories (group directory)	70
Call forwarding	73
Using call forwarding	73
Forwarding calls for a different terminal	81
Mailbox	83
More features	85

Making calls using project assignment (cost billing)	85
Caller ID suppression	88
Index	97
Open Source Software	101



Not all functions described in the user guide are available in all countries or from all network providers.

Overview



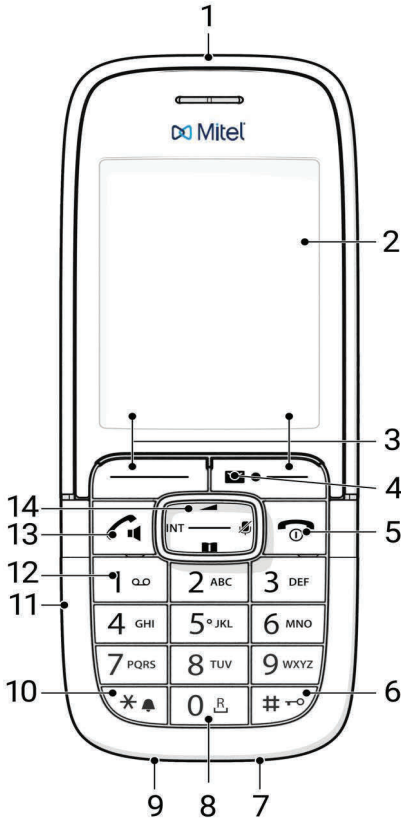

Handset











- 1 **Function key**
- 2 **Display**
- 3 **Display keys**
Various functions, depending on the operating situation
- 4 **Message key**
Access to the call and message lists;
Flashes: new message or new call

- 5 **End call key / On/off key**
End call; cancel function;
Go back one menu level ▶ Press **briefly**
Return to idle status ▶ Press and **hold**
Switch the handset on/off (in idle status) ▶ Press and **hold**
- 6 **Hash key / Lock key**
Lock/unlock the keypad (in idle status) ▶ Press and **hold**
Toggle between upper/lower case and digits (when inputting text) ▶ Press **briefly**
Insert a dialling pause ▶ Press and **hold**
- 7 **Microphone**
- 8 **Recall key**
Consultation call (flash) ▶ Press and **hold**
- 9 **USB connection socket**
For data exchange between the handset and PC
- 10 **Star key**
Enable/disable the ring-tone ▶ Press and **hold**
Open special characters table (when inputting text) ▶ Press **briefly**
- 11 **Headset connection**
(3.5 mm jack)
- 12 **Key 1**
Select network mailbox ▶ Press and **hold**
- 13 **Talk key / Handsfree key**
Accept call; dial number displayed; switch between receiver and handsfree mode
Open the redial list ▶ Press **briefly**
Start dialling ▶ Press and **hold**
- 14 **Control key / Menu key**
Open a menu; navigate in menus and entry fields; access functions (depending on the situation)

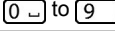
Illustration in the user guide

	Warnings, which if not heeded, can result in injury to persons or damage to devices.
	Important information regarding function and appropriate handling or functions that could generate costs.
	Prerequisite for being able to carry out the following action.
	Additional helpful information.







Keys

	Talk key		Handsfree key
	End call key		Number / letter keys
	Control key rim / centre		Message key
	Recall key		Star key
	Hash key		
OK, Back, Select, Change, Save, ...		Display keys	











Procedures

Example: Switching Auto answer on/off

-  ▶ ... use  to select  **Settings** ▶ **OK** ▶  **Telephony** ▶ **OK** ▶ **Auto Answer** ▶ **Change** (= on)

Step	Follow this procedure
• 	When in idle status press the centre of the control key. The main menu opens.
•  	Navigate to the  icon using the control key  .
• OK	Select OK to confirm. The submenu Settings opens.
•  Telephony	Select the Telephony entry using the control key  .
• OK	Select OK to confirm. The submenu Telephony opens.
• Auto Answer	The function to switch Auto answer on/off appears as the first menu item.
• Change	Select Change to activate or deactivate. Function is activated <input checked="" type="checkbox"/> / deactivated <input type="checkbox"/> .

Safety precautions

	<p>Read the safety precautions and the user guide before use.</p> <p>Comprehensive user guides for all telephones and telephone systems as well as for accessories can be found online at https://wiki.unify.com/wiki/DECT_Handsets in the Support category. We thereby help to save paper while providing fast access to the complete up-to-date documentation at any time.</p>
	<p>The device cannot be used in the event of a power failure. In case of a power failure it is also not possible to make emergency calls.</p> <p>Emergency numbers cannot be dialled if the keypad/display lock is activated!</p>
	<p>Use only rechargeable batteries that correspond to the specification (see list of permitted batteries → https://wiki.unify.com/wiki/DECT_Handsets). Never use a conventional (non-rechargeable) battery or other battery types as this could result in significant health risks and personal injury. Rechargeable batteries, which are noticeably damaged, must be replaced.</p>
	<p>The handset must not be operated if the battery cover is open.</p> <p>Ensure that the batteries can not be short-circuited by objects in the battery compartment</p>
	<p>Do not use the devices in environments with a potential explosion hazard (e.g. paint shops).</p>
	<p>The devices are not splashproof. For this reason do not install them in a damp environment such as bathrooms or shower rooms.</p>
	<p>Use only the power adapter indicated on the device.</p> <p>Whilst charging, the power socket must be easily accessible.</p>
	<p>Remove faulty devices from use or have them repaired by our Service team, as these could interfere with other wireless services.</p>
	<p>Do not use the device if the display is cracked or broken. Broken glass or plastic can cause injury to hands and face. Send the device to our Service department to be repaired.</p>
	<p>Keep small cells and batteries, which can be swallowed, out of the reach of children.</p> <p>Swallowing a battery can lead to burns, perforation of soft tissue and death. Severe burns can occur within 2 hours of swallowing.</p> <p>In the case of a swallowed cell or battery, seek medical care immediately.</p>



Using your telephone may affect nearby medical equipment. Be aware of the technical conditions in your particular environment, e.g. doctor's surgery. If you use a medical device (e.g. a pacemaker), please contact the device manufacturer. They will be able to advise you regarding the susceptibility of the device to external sources of high frequency energy (for the specifications of your OpenScope DECT Phone SL7 product see "Technical data").



If a USB adapter cable is included, only use a USB power supply (5Volt) with USB-A connection. The use of other voltage sources e.g. PC's with USB connection can cause damage.

If a plug-in power supply is included, please use this power supply.

Getting started

Contents of the package

- 1 handset
- 1 battery cover (rear cover for the handset)
- 2 rechargeable batteries (AAA)
- 1 belt clip
- 1 user guide



The charging cradle is designed for use in closed, dry rooms within a temperature range of +5°C to +45°C.

Never expose the telephone to heat sources, direct sunlight or other electrical devices.

Protect your telephone from moisture, dust, corrosive liquids and vapours.

The device's feet do not usually leave any marks on surfaces. However, due to the multitude of different varnishes and polishes used on furniture, contact marks on the surfaces cannot be completely ruled out.

Handset

Connecting the charging cradle

- Connect the flat plug of the power adapter.
- Plug the mains unit into your power socket.

To remove the plug from the charging cradle again:

- Disconnect the power adapter from the mains power supply.
- Press the release button.
- Pull out the plug.

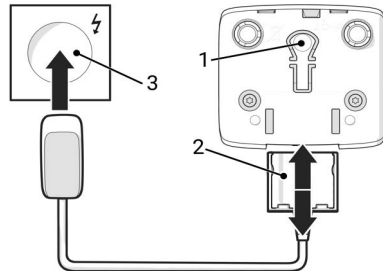

Setting up the handset for use

The display is protected by a plastic film. ▶ Please remove the protective film!

Inserting the batteries



Only use **rechargeable batteries** otherwise major health risks and injury may result. For example, the outer casing of the batteries could be damaged beyond repair or the batteries could explode. The device could also malfunction or be damaged as a result of using batteries that are not of the recommended type.

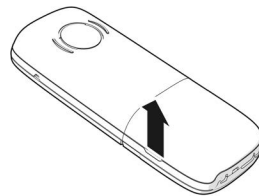
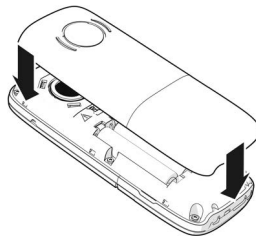
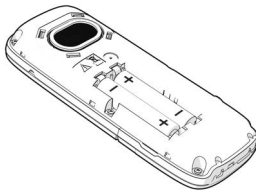

- Insert the batteries (for correct +/- direction, see diagram).
 - Fit the battery cover from the top.
 - Press the cover until it clicks into place.
- Re-open the battery cover:
- Insert a fingernail into the notch at the bottom of the cover and slide it upwards to remove.

Charge the battery

- Charge the battery fully prior to first use in the charging cradle or using a standard USB mains adapter.

The battery is fully charged when the power icon  disappears from the display.



The battery may heat up during charging. This is not dangerous.

After a time, the charge capacity of the battery will decrease for technical reasons. Switch the handset off if you are not using it for a couple of days.

If you are not using the handset for a couple of weeks, switch it off and remove the battery.

As soon as power is applied to the handset, a Setup wizard starts.

Setting the display language

- Press the control key  until the language required is selected on the display, e.g. **English** ▶ press the display key **OK**

You can also change the display language later on in the **Settings** menu.

Registering a handset







On the handset

You require the 4-digit system PIN (registration code).

If the handset is not yet registered with a base:

- **Register** . . . A search is performed for a base ready for registration ▶  enter the system PIN ▶ **OK**







If the handset is already registered with a base:

-  ▶   **Settings** ▶ **OK** ▶  **Registration** ▶ **OK** ▶  **Register Handset** ▶ **OK** . . . A search is performed for a base ready for registration ▶  enter the system PIN ▶ **OK**

Once registration is complete, the handset returns to idle mode. Your phone is now ready for use.



The handset can be registered with up to four base stations. Changing the base:

-  ▶   **Settings** ▶ **OK** ▶  **Registration** ▶ **OK** ▶  **Select Base** ▶ **OK** ▶  select the base ▶ **OK**

Attaching the belt clip

The handset has 2 notches on each side for attaching the belt clip.

- Attaching the belt clip: ▶ Press the belt clip onto the back of the handset so that the tabs on the belt clip click into place in the notches.
- Removing the belt clip: ▶ Press the centre of the belt clip firmly with your right thumb. ▶ Push the nail of your left thumb up between the clip and the casing. ▶ Slide the clip upwards to remove.

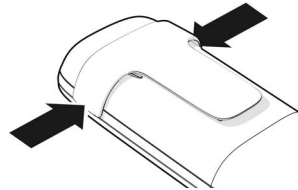

Connecting the headset

- Connect the headset with 3.5 mm jack to the left side of the handset.

or

- Connect headset via Bluetooth (→ p. 36)

Setting the headset volume: → p. 41

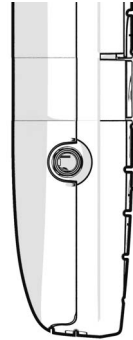

Connecting the USB data cable

For data exchange between the handset and PC:

- Connect the USB data cable with USB-C plug into the USB-C socket at the bottom of the handset.



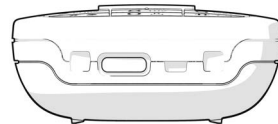

Connect the handset directly to the PC, **not** via a USB hub.



Using the telephone

Getting to know your telephone

Switch the handset on/off

- Switch on: • When the handset is switched off, press and **hold** the End call key 
- Switch off: • When the handset is in idle status, press and **hold** the End call key 

Lock/unlock the keypad

The keypad lock prevents any accidental use of the telephone.

Lock/unlock the keypad: ▶  Press and **hold**

Keypad lock activated: the following symbol appears 

PIN-protected keypad lock

Once you have assigned a PIN (not 0000) to the handset, you must enter this PIN to cancel the keypad lock.

Setting up a handset PIN: → p. 46

Define emergency numbers that can be dialled even when the keypad lock is PIN-protected: → p. 44



If a call is indicated on the handset, the keypad automatically unlocks and you can accept the call. It then locks again when the call is finished.





All data will be erased if you forget the PIN and try to unlock the handset.

Control key



The control key enables you to navigate the menus and input fields, and also to call up certain functions depending on the situation.

In the description below, the side of the control key (up, down, right, left) that you have to press in the different operating situations is marked in black, e. g.  for "press right on the control key" or  for "press the centre of the control key".

When the phone is idle

Open the main menu

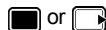



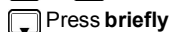



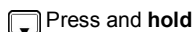







Open the list of available online directories (such as the central directory, the directory of a provider or a company directory)



Open the local directory:



Open the handset menu	
Set the voice volume for receiver / handsfree function	 Press briefly
Open the profile selection	 Press and hold
Set the microphone sensitivity	 Press and hold
In submenus, selection and entry fields	
Confirm a function	
Navigate a line up/down	 / 
Select an option, move the cursor to the left/right	 / 
During a call	
Open the local directory:	
Open the handset menu	
Mute the microphone	 Press briefly
Set the microphone sensitivity, mute the microphone	 Press and hold
Change the voice volume for receiver / handsfree function	

Display keys

The display keys perform a range of functions depending on the operating situation.

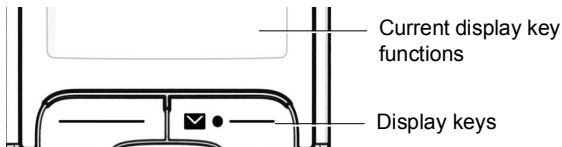

Display key icons → p. 54



The display keys have a function preset by default in idle status.
Change the assignment: → p. 45

Menu guidance

The functions of your telephone are displayed in a menu that consists of several levels.

Menu overview → p. 58

Selecting/confirming functions

Confirm selection using **OK** or press the centre of the control key 



One menu level back using **Back**

Change to idle status  Press and **hold**

Switch function on/off using **Change** on  / off 

Activate/deactivate option using **Select** activated  / not activated 

Main menu

In idle status: ▶ Press the **centre** of the control key  ▶  select a submenu ▶ **OK**

The main menu functions are shown in the display as icons. The icon for the selected function is highlighted in colour and the name of the associated function appears in the display header.

Submenus

The functions in the submenus are displayed as lists.

To access a function: ▶  select a function ▶ **OK**

Return to the previous menu level:

- Press the display key **Back**

or

- Press the End call key  **briefly**

Returning to idle status



- Press and **hold** the End call key 





If a key is not pressed, after 2 minutes the display **will automatically** change to idle status.

Entering text



Input position

- Use  to select an entry field. A field is activated when the cursor is blinking inside it.
- Use  to move the position of the cursor.

Correcting incorrect entries



- Delete **characters** to the left of the cursor: ▶  Press **briefly**
- Delete **words** to the left of the cursor: ▶  Press and **hold**

Entering letters/characters

Multiple letters and numbers are assigned to each key between  and  and the  key. As soon as a key is pressed, the possible characters are displayed at the bottom of the display. The selected character is highlighted.

- Selecting letters/numbers: ▶ Press the key **briefly** several times in succession
- Switch between lower case, upper case and number entry mode: ▶ Press the hash key 

When editing a directory entry, the first letter and each letter following a space is automatically in upper case.

- Entering special characters: ▶ Press the star key  ▶  navigate to the desired character ▶ **Insert**
- Enter numbers to text field: ▶ Hold the desired digit key



The availability of special characters depends on the language setting.

Making calls

You can initiate or answer calls on a handset across the whole wireless network and change base station during a call (handover).



The handset is located in the wireless cell of at least one of the base stations registered with the phone system.

The handset is assigned a send and receive connection.

Making calls

- Enter the number ▶ Press **briefly** the **Talk** key

or

- Press and **hold** the **Talk** key ▶ enter the number

The connection is established over the SIP link assigned to the handset.

Cancel dialling: ▶ Press the **End** call key



If the display backlight is deactivated, you can reactivate it by pressing any key. **Digit keys** that are pressed appear in the display for pre-dialling, **other keys** have no further function.

Dialling from the redial list

The redial list contains the 20 numbers last dialled with the handset.

- **Briefly** press the **Talk** key . . . The redial list is opened ▶ select the entry ▶ Press the **Talk** key

If a name is displayed:

- **View** . . . The number is displayed ▶ Use as required to scroll through the numbers ▶ At the phone number required, press the **Talk** key

Managing entries in the redial list

- Briefly press the **Talk** key . . . The redial list is opened ▶ select an entry ▶ **Options** . . . Possible options:

Copy entry to directory:

- **Copy to Directory** ▶ **OK**

Copy the number to the display:

- **Display Number** ▶ **OK** ▶ Use as required to change or add . . . save in the directory as a new entry



Delete the selected entry:

- **Delete entry** ▶ **OK**

Delete all entries:

- **Delete List** ▶ **OK**

Set automatic redial:

-  **Automatic Redial** ► **OK** . . . The selected number is automatically dialled at fixed intervals (at least every 20 seconds). The handsfree key flashes, "open listening" is activated.
 The participant answers: ►  Press the **Talk** key . . . The function is ended
 The subscriber does not answer: The call is interrupted after around 30 secs. The function is terminated after pressing any key or after ten unsuccessful attempts.

Dialling from a call list

The call lists (→ p. 23) contain the most recent accepted, outgoing and missed calls.

-  ►  **Call Lists** ► **OK** ►  select the list ► **OK** ►  select an entry ►  press the **Talk** key



The call lists can be displayed directly by pressing the display key **Calls** if the relevant function has been assigned to the display key.

The Missed calls list can also be opened by pressing the Message key .

Incoming calls

An incoming call for the connection assigned to your handset is indicated by ringing, by a display on the screen and by the flashing Talk / Handsfree key .

Accept the call: • Press the Talk key  or ► **Accept**

If **Auto Answer** is enabled:

- Remove the handset from the charging cradle

Disable ringtone: • Silence . . . You can accept the call as long as it is displayed on the screen

Reject the call: • Press the **End** call key 

Information about the caller

If it is sent, the number of the caller is displayed. If the caller's number is saved in a directory, the name is displayed.



During a conversation

Handsfree mode

Activating/deactivating handsfree mode during a call and when establishing a connection:

- Press the handsfree key 

Placing the handset in the charging cradle during a call:

- Press and **hold** down the handsfree key  ► Place the handset in the charging cradle ► **hold**  for a further 2 seconds

Call volume

Applies for the mode currently being used (handsfree, receiver or headset):

- Press  ► use  to set the volume ► **Save**



The setting is automatically saved after around 3 seconds, even if Save is not pressed.

Muting the microphone

When the microphone is switched off, callers will no longer hear you.

Switch the microphone on/off during a call: ► Press .

Adjust the microphone sensitivity



Adjust the microphone sensitivity for the receiver or wired headset during a call.

-  press and **hold** ► **Mic Sensitivity** ►  set the sensitivity ► **Save**







Changing without saving means the change only applies for the current call.

Permanent setting of the microphone sensitivity when the phone is idle:

-  press and **hold** ►  select **Earpiece / Corded headset / Bluetooth headset** ►  set the sensitivity ► **Save**

or

-  ►  **Audio Settings** ► **OK** ►  **Mic Sensitivity** ► **OK** ►  select **Earpiece / Corded headset** ►  set the sensitivity ► **Save**













Set the acoustic profile to loud surroundings:

- Press and **hold**  ►  set the sensitivity ► **Save**

Call lists







The telephone saves different types of calls (missed, accepted and outgoing calls) in lists.

Activating/deactivating the local call lists

-  ▶ Press buttons       ... ▶... then to ...
 - activate:
 -   
 - deactivate:
 -   





List entry

The following information is displayed in the list entries:

- The list type (in the header)
- Icon for the type of entry:
 -  **Missed calls,**
 -  **Accepted calls,**
 -  **Outgoing calls** (redial list)
- Caller's number. If the number is stored in the directory, the name and number type ( **Phone (Home)**,  **Phone (Office)**,  **Phone (Mobile)**) are shown instead. In the event of missed calls, the number of missed calls from this number is also shown in square brackets.
- Connection by which the call was received/made
- Date and time of call (if set)

Opening the call list

Via the menu:

-  ▶ ... use  to select  **Call Lists** ▶ **OK** ▶ ... use  to select the list ▶ **OK**

Via the Message key (missed calls):

- Press the **Message** key  ▶  **Missed Calls:** ▶ **OK**

Calling back a caller from the call list

-  ▶   **Call Lists** ▶ **OK** ▶  select list ▶ **OK** ▶  select entry ▶ Press the **Talk** key 



Additional options

-  ▶ ... use  to select  **Call Lists** ▶ **OK** ▶ ... use  to select list ▶ **OK** ... possible options:



View an entry:

- ... use  to select entry ▶ **View**

Copy the number to the directory:

- ... use  to select entry ▶ **Options** ▶  **Copy to Directory**

Delete an entry:

- ... use  to select entry ▶ **Options** ▶  **Delete entry** ▶ **OK**

Delete list:

- Options** ▶  **Delete List** ▶ **OK** ▶ **Yes**

Message lists

Notifications about missed calls, messages on the network mailbox and missed alarms are saved in the messages list.

As soon as a **new message** arrives, an advisory tone will sound. The Message key  also flashes (if activated).

Icons for message types and the number of new messages are shown on the idle display.

Notification for the following message types is available:

 on the network mailbox

 in the missed calls list

 in the missed alarms list



The icon for the network mailbox is always displayed, provided the number is stored in the telephone. The other lists are only displayed if they contain messages.

Display messages:

- Press the Message key  . . . Messages lists that contain messages are displayed, **Mailbox:** is always displayed

An entry is marked in **bold**: new messages are available. The number of new messages is shown in brackets.

An entry is **not** marked in bold: no new messages. The number of old messages is shown in brackets.

- . . . use  to select a list ► **OK** . . . the calls or messages are listed

Network mailbox: The network mailbox number is dialled.



The message list contains an entry for every answer machine assigned to the handset, e.g. for a network mailbox.

Directories

Open directories

Open directories with the Directory key

- Press the Directory key  (bottom of control key)

Opening directories via the menu

Local directory:

-  ►   **Directory** ► **OK**

Local handset directory

The local directory is unique to the handset.















Directory entries

Number of entries: Maximum 500

Information: First and last names, up to three phone numbers, email address, anniversary with signalling, VIP ringtone with VIP icon, CLIP image

Length of the entries: Numbers: max. 32 digits
First and last names: max. 16 characters
Email address: max. 64 characters

Creating an entry

-  ►  **<New Entry>** ► **OK** ►  switch between the entry fields
Name:
-  enter the first and/or last name
Numbers:
-  **Tel.1 - Type** ►  select a number type (**Home**, **Office** or **Mobile**) ►  ►  enter a number
Enter more numbers: ►  toggle between the entry fields **Tel.1 - Type/Tel.2 - Type/Tel.3 - Type** ►  enter a number
eMail:
-  enter the e-mail address
Anniversary:
-  activate/deactivate **Anniversary** ►  enter date and time ►  select type of alert (**Optical only** or a ringtone)

Caller Melody (VIP):

-  select the ringtone that will indicate a call from the participant . . . if a **Caller Melody (VIP)** has been assigned, the entry will appear in the directory with the **VIP** icon.

Caller Picture:

-  select a picture that is to be displayed during a call from the participant (→ Resource Directory).

Save entry: ▶ **Save**





The entry is only valid if it contains at least one number.





For **Caller Melody (VIP)** and **Caller Picture**: the telephone number of the caller must be supplied.

Searching for/selecting a directory entry

-  ▶  browse searched names

or

-  ▶  enter initial letters (max. 8 letters) . . . the display jumps to the first name starting with these initial letters ▶  continue browsing to the desired entry, if needed

Scroll through directory: ▶  ▶ Press and **hold** 

Displaying/changing an entry



-  ▶  select entry ▶ **View** ▶  select the field to be changed ▶ **Edit**

or

-  ▶  select an entry ▶ **Options** ▶ **Edit Entry** ▶ **OK**

Deleting entries

Delete the **selected** entry:

-  ▶  select an entry ▶ **Options** ▶  **Delete entry** ▶ **OK**

Delete all entries:

-  ▶ **Options** ▶  **Delete All** ▶ **OK** ▶ **Yes**

Setting the order of the directory entries

Directory entries can be sorted by first name or surname.

-  ▶ **Options** ▶  **Sort by Surname / Sort by First Name**

If no name was entered, the default telephone number is shown in the surname field. These entries appear at the beginning of the list, regardless of how the entries are sorted.

The sort order is as follows:

Space | Digits (0-9) | Letters (alphabetically) | Other characters.

Displaying the number of entries available in the directory





-  ▶ **Options** ▶  **Available Memory** ▶ **OK**

Copying number to the directory

Copy numbers to the directory:

- From a list e.g. the call list or the redial list
- When dialling a number

The number is displayed or highlighted.

- Press the display key  or **Options** ►  **Copy to Directory** ► **OK** . . . possible options:
 - Create a new entry:
 - **<New Entry>** ► **OK** ►  select number type ► **OK** ► complete entry ► **Save**
- Add number to an existing entry:
-  select an entry ► **OK** ►  select number type ► **OK** . . . the number is entered or a prompt to overwrite an existing number is displayed ► if required, answer the prompt with Yes/No ► **Save**





Copying a vCard using Bluetooth

Copy directory entries in vCard format, e.g. to exchange entries with a mobile phone.



Bluetooth mode is activated

The other handset/mobile phone supports Bluetooth.

-  ►  select an entry if needed ► **Options** ►  **Copy entry / Copy all** ►  **vCard via Bluetooth** . . . the Known Devices list is displayed ►  select device ► **OK**

Receiving a vCard using Bluetooth

If a device in the Known Devices list sends a vCard to your handset, a directory entry is automatically created and a message is shown in the display.

If the sending device is not in the list: ► use  to enter the PIN of the sending Bluetooth device ► **OK** . . . the copied vCard is available as a directory entry

Transferring contacts from other Bluetooth devices

Use the contacts of devices that are connected over Bluetooth, such as smartphones.









Bluetooth is enabled, and the other device is entered as a trustworthy device, connected over Bluetooth and supports the exchange of contacts.

On the smartphone: ► From the Bluetooth settings for the OpenScape DECT Phone SL7, enable access to the contacts





The remote directory is only opened for viewing. Changing and deleting entries are not possible.

-  ►   **Directory** . . . The list of available directories is displayed ►
 **Bluetooth Directory** ► **OK** . . . The trustworthy devices with enabled contacts are displayed ►  **Select**



Search for a contact: •  Scroll through the list or enter the initial letters

See the details: •  Select the entry ► **View**

Dial a phone number: •  Select the entry ► Press the **Talk** key 

or: ► **Options** ►  **Display Number** ► **OK**

•  Select the number if required ► **OK**

Transfer a contact: •  Select an entry ► **Options** ►  **Copy entry** ► **OK** ►

 Select the phone number as required ► **OK**

Transfer another contact: ► **Yes**

End a transfer: ► **No**

Transfer all contacts: • **Options** ►  **Copy all** ► **OK** ►  Select the phone number as required ► **OK**



Contacts without a phone number are ignored. First and last names and a maximum of three phone numbers are displayed (Mobile, Home, Office). Other information is ignored.

The number of contact entries displayed and the sorting order are dependent on the device connected and the access permissions defined on it.

Answering machine

The answering machine takes incoming calls for the handset.

Requirements

The following settings are required so that you can receive and listen to voice messages:

On the phone system

- A network mailbox is set up for the connection assigned to the handset.

On the handset



- In the handset configuration, the phone number is entered and the network mailbox is enabled.

If necessary, contact the administrator of the DECT network.

Enter/change numbers from the handset

-  ►   **Answer Machine** ► **OK** ►  **Network Mailbox** ► **OK** ►  enter
or change the number of the network mailbox ► **Save**



Play messages on the handset

-  Press and hold the  button

or

- Press the Messages  key ► **OK**

or



-  ►   **Answer Machine** ► **OK** ► **Play Messages** ► **OK**

Listen to announcement over speaker: ► Press the Speaker  button

Additional functions

Sound profiles

The telephone has sound profiles for adapting the handset to the environmental conditions: **Profile Loud**, **Profile Silent**, **Profile Personal**. You can use the **Do not disturb** profile to prevent the handset signalling an incoming call.

- Press and **hold**  . . . The profile currently set is shown
- Switch between profiles using 

or

-  select a profile ► **OK**





Set the microphone sensitivity to loud surroundings:

- Press and **hold**  during a call

Profile "Do not disturb"

- Press and **hold**  ►  select the profile

or

-  ►   **Audio Settings** ► **OK** ►  **Do Not Disturb** ► **Change** (= On)
- The idle display shows "**Do not disturb**" active. The status bar shows 
- Incoming calls are not signalled but show up in the call list as missed calls.
- Most messages are blocked. Exceptions: Appointments, alarm clock and anniversaries.



An incoming call occupies a line even if it is not signalled. If all the lines on the base are occupied, calls cannot be made.

Sound profiles

The profiles are set as follows by default:

Default setting		Profile Loud	Profile Silent	Profile Personal
Silent alert		On	Same as Profile Personal	Off
Ringtone		On	Off	On
Ringtone volume	Internal	5	Off	5
	External	5	Off	5
Handset volume	Receiver	5	3	3
	Handsfree	5	3	3
Advisory Tones	Key click	Yes	No	Yes
	Battery tone	Yes	Yes	Yes
	Confirmation tone	Yes	No	Yes

Activate alert tone for an incoming call for **Profile Silent**: ▶ after switching to **Profile Silent** press the display key **Beep** . . . the icon  appears in the status bar



The set profile remains set when switching the phone off and back on.

Changes to the settings listed in the table:

apply in the Profile **Loud** and **Profile Silent** profiles as long as the profile is not changed.

- are permanently saved in **Profile Personal** for this profile.

Calendar

You can remind yourself of up to **30 appointments**.

In the calendar, the current day is outlined in white; on days with appointments, the numbers are displayed in colour. When a day is selected, it will be outlined in colour.

Saving appointments to the calendar





-  ▶  ▶  **Organizer** ▶ **OK** ▶  **Calendar** ▶ **OK** ▶  select desired day ▶ **OK** . . . then



Switch on/off:

- **Activation:**  select **On** or **Off**



Enter date:

-  **Date** . . . the selected day has been pre-set ▶  enter new date



Enter time:

-  **Time** ▶  enter hours and minutes of the appointment

Set name:

-  **Text** ▶  enter a description of the appointment (e.g. evening meal, meeting)

Set alarm tone:

-  **Signal** ▶  select the melody of the reminder alarm or deactivate the acoustic signal

Save appointment: • **Save**



If an appointment has already been entered: ▶  **<New Entry>** ▶ **OK** ▶ then enter information for the appointment.

Notification of appointments/anniversaries

Anniversaries are transferred from the directory and displayed as an appointment. An appointment/anniversary is displayed in idle status and the selected ringtone plays for 60 seconds as a notification.

Acknowledge and stop the reminder: ▶ Press the display key **Off**



During a call, a reminder is indicated on the handset **once** with an advisory tone on the handset.



Displaying missed appointments/anniversaries

The following appointments and anniversaries are saved in the **Missed Appts** list:

- The appointment/anniversary call was not acknowledged.
- The appointment/anniversary was notified during a phone call.
- The handset was switched off at the time of the appointment/anniversary.

The last 10 entries are stored. The  icon and the number of new entries are shown in the display. The most recent entry appears at the top of the list.

Opening the list

- Press the Message key  ►  **Missed Appts:** ► **OK** ►  browse through the list of any appointments





or

-  ►  **Organizer** ► **OK** ►  **Missed Appts** ► **OK**

Each entry is displayed with the number or name, date and time. The most recent entry appears at the top of the list.

Delete an appointment/anniversary: ► **Delete**

Displaying/changing/deleting stored appointments

-  ►  **Organizer** ► **OK** ►  **Calendar** ► **OK** ►  select day ► **OK** . . . the appointment list is displayed ►  select date . . . possible options:

Display appointment details:

- **View** . . . the appointment settings are displayed

Change appointment:

- **View** ► **Edit**
or ► **Options** ►  **Edit Entry** ► **OK**

Activate/deactivate appointment:

- **Options** ►  **Activate/Deactivate** ► **OK**

Delete appointment:







- **Options** ►  **Delete entry** ► **OK**

Delete all appointments for a day:

- **Options** ►  **Delete all Appts.** ► **OK** ► **Yes**

Timer

Setting the timer (countdown)

-  ►   **Organizer** ► **OK** ►  **Timer** ► **OK** . . . then
 - Enable/disable:
 - Activation:  select **On** or **Off**
 - Set the duration:
 -  **Duration** ► use  to enter the hours and minutes for the timer
Min.: 00:01 (one minute); Max.: 23:59 (23 hours, 59 minutes)
 - Save the timer:
 - **Save**

The timer starts the countdown. In the idle display, icon  and the remaining hours and minutes are displayed until one minute is left. From this point, the remaining seconds are counted down. At the end of the countdown, the alarm is triggered.













Disabling/repeating the alarm

- Switch off the alarm:
 - **Off**
- Repeat the alarm:
 - **Restart** . . . the timer display is displayed again ► set another duration as required ► **Save** . . . the countdown is restarted

Alarm clock



Activating/deactivating the alarm clock and setting the wake-up time

-  ►   **Alarm Clock** ► **OK** . . . then
 - Switch on/off:
 - **Activation:**  select **On** or **Off**
 - Setting the wake-up time:
 -  **Time** ►  enter hours and minutes
 - Set days:
 -  **Occurrence** ►  switch between Monday-Friday, Once and Daily
 - Set the volume:
 -  **Volume** ►  set volume in 5 levels s or select crescendo (increasing volume)
 - Set alarm:
 -  **Melody** ►  select a ringtone for the alarm
 - Save settings:
 - **Save**

When the alarm clock is activated, the icon  and the wake-up time are displayed in idle display.

Alarm

An alarm is shown on the display and indicated by the selected ringtone melody. The alarm sounds for 60 seconds. If no key is pressed, the alarm is repeated after 5 minutes. After the second repetition, the alarm call is deactivated for 24 hours.



During a call, the alarm is only indicated by a short tone.

Switching off/repeating the alarm after an interval (snooze mode)

Deactivate the alarm: ► **Off**

Repeat the alarm (snooze mode): ► Press **Snooze** or any key . . . the alarm is switched off and repeated after 5 minutes.

Protection against unwanted calls

Time control for external calls



Date and time have been set.

Enter a time period during which the handset should suspend ringing to indicate external calls e.g. during the night.

- ► **Audio Settings** ► **OK** ► **Ringtones (Handset)** ► **OK** ► **Time Control** ► **Edit** . . . then

- Switch on/off:
 - select **On** or **Off**
- Enter time:
 - switch between Suspend ring. from and Suspend ring. until ► enter start and end in 4-digit format
- Save:
 - **Save**



The time control only applies to the handset for which the setting is configured. The telephone will continue to ring for numbers that have been assigned to a VIP group in the directory.



Protection from anonymous callers

The handset will not ring if callers' numbers are not revealed.

- ► **Audio Settings** ► **OK** ► **Ringtones (Handset)** ► **OK** ► **Anon. Calls Silent** ► **Change** = on) . . . the call is only signalled on the display



Switch off ringtone when in charging cradle

The handset will not ring when placed in the charging cradle. The call is only indicated on the display.

-  ►  **Audio Settings** ► OK ►  **Ringtones (Handset)** ► OK ► **Silent Charging** ► **Change** = ringtone is switched off when in charging cradle)

Disable the ringtone (do not disturb)

You can use the **Do Not Disturb** function to prevent the handset signalling an incoming call.

-  ►  **Do Not Disturb** ► OK ►  **Do Not Disturb** ► **Edit** = enabled)
- The idle display shows "**Do not disturb**" active.
- Incoming calls are not signalled but show up in the call list as missed calls.
- Most messages are blocked. Exceptions: Appointments, alarm clock and anniversaries.



An incoming call occupies a line even if it is not signalled. If all the lines on the base are occupied, calls cannot be made.

Resource Directory









Sounds for ringtones and images that can be used as caller pictures (CLIP pictures) or as a screensaver are saved in the handset's resource directory. A range of monophonic and polyphonic sounds and pictures have been pre-set.

Media types

Type	Format
Sound Ringtones Monophonic Polyphonic Imported sounds	Internal Internal Internal WMA, MP3, WAV
Picture CLIP-picture Screensaver	BMP, JPG, GIF 240 x 172 pixels 240 x 320 pixels

If insufficient memory is available, you must delete one or more pictures or sounds before others can be saved.

Managing images (for screensaver and CLIP) and sounds





-  ►   **Additional Features** ► **OK** ►  **Resource Directory** ► **OK** ... possible options:
 - View image:
 -  **Screensavers / Caller Pictures** ► **OK** ►  select picture ► **View** ... the selected picture is displayed
 - Play sound:
 -  **Sounds** ► **OK** ►  select sound ... the selected sound is played
 - Set volume: ► **Options** ► **Volume** ► **OK** ►  select volume ► **Save**



The relevant options are not available if a picture/sound cannot be deleted.

Check memory

Display the available memory for screensavers and CLIP-pictures.

-  ►   **Additional Features** ► **OK** ►  **Resource Directory** ► **OK** ►  **Capacity** ► **OK** ... the percentage of available memory is displayed

Bluetooth

The handset is able to use Bluetooth™ to communicate wirelessly with other devices that also use this technology, e.g. to connect a Bluetooth headset or hearing aid.



Bluetooth is activated and the devices have been registered to the handset.

The following devices can be connected:

- A Bluetooth headset or hearing aid



The headset / hearing aid has the Headset or Handsfree **profile**. If both profiles are available, the handsfree profile is used to communicate.

It may take 5 seconds to establish a connection to the headset, whether a call is accepted using the headset or transferred to the headset, or a call is made from the headset.

- Up to 30 data devices (PCs, tablets or mobile phones) for the transmission of address book entries as a vCard or for the exchange of data with the computer.

In order for telephone numbers to be used further, the area code (international and local area code) must be saved to the telephone.

Operating Bluetooth devices → device user guides

Activating/deactivating Bluetooth mode

- ► ► **Bluetooth** ► **OK** ► ► **Activation** ► **Change** (☑ = activated)

If the local area code is still not saved: ► enter local area code ► **OK**

When in idle status, the activated Bluetooth mode is indicated on the handset by the icon.

Making a device visible/invisible

When Bluetooth is enabled, the handset is visible to Bluetooth devices in range for 5 minutes. It is then invisible after this time.

Making a device visible again:

- ► ► **Bluetooth** ► **OK** ► ► **Visibility** ► **Change** (☑ = enabled)

The icon in the status bar flashes whilst the handset is visible.



Even when the handset is invisible, requests from devices known as trustworthy are accepted.

Registering Bluetooth devices

The distance between the handset in Bluetooth mode and the active Bluetooth device (headset or data device) should not exceed 10 m.



Only one headset / hearing device can be registered. When more than one headset is found, enable the one required using the checkbox (☑ = enabled).

- ► ► **Bluetooth** ► **OK** ► ► **Search Devices** ► **OK** ... the search starts (may take up to 30 seconds) ... the names of found devices are displayed ... possible options:

Register device: • **Options** ► ► **Trust Device** ► **OK**

The subsequent process is dependent on the device to which the connection is being made. Normally, both devices show the same authentication code.

- Confirm the authentication code on both devices ... The devices are connected. The device is included in the list of known devices.

Showing information:

- Select the device as required ► **View** ... The device name and address are displayed, as well as functions possible for this device

Repeat search: • **Options** ► **Repeat Search** ► **OK**

Cancel search: • **Cancel**

Editing the list of known (trusted) devices

Open the list

- ► ► **Bluetooth** ► **OK** ► ► **Known Devices** ► **OK** ... the known devices are listed, an icon indicates the type of device



•Bluetooth headset



•Bluetooth data device

If a device is connected, the relevant icon is shown in the display header instead of .

Edit an entry

- ► ► **Bluetooth** ► **OK** ► ► **Known Devices** ► **OK** ► select entry ... possible options:

View an entry: • **View** ... the device name and device address are displayed ► Press **OK** to go back

De-registering a device:

- **Options** ► **Delete entry** ► **OK**

Deregister all devices:

- **Options** ► **Delete List** ► **OK**

Edit name:

- **Options** ► **Edit Name** ► **OK** ► edit name ► **Save**



If an active Bluetooth device is de-registered, it may try to re-connect as a "non-registered device".

Rejecting/accepting a non-registered Bluetooth device

When Bluetooth is enabled or Visibility is activated, the handset is only visible to other Bluetooth devices for 5 minutes (→ p. 36). A device is only able to request a connection during this time. Also, a connection can only be established when a register process is started.

- Start a register process as described in Section Registering Bluetooth devices.

Changing the Bluetooth name of the handset

The handset is shown by this name on another Bluetooth device.

-  ►  ► **Bluetooth** ► **OK** ►  Own Device ► **OK** . . . the name and the device address are shown ► **Change** ►  change the name ► **Save**

Usage as a Bluetooth beacon

The OpenScape DECT Phone SL7 can be used as a Bluetooth beacon. It can therefore be used in systems in which BLE (Bluetooth Low Energy) is used for communication, such as for localising the device, asset tracking, use in an alarm system, . . .

The Beacon function is enabled and set up by an Administrator. Which function the handset assumes here is dependent on the system in which it is used.

When the Beacon function is enabled on the handset, the  icon is shown in the status bar.

For further information, contact your Administrator.

Adjusting the telephone settings

Changing the language

- ► **Settings** ► **OK** ► **Language** ► **OK** ► select language ► **Select** (= selected)

If the handset has been set to an incomprehensible language:

- ► Press the keys slowly one after the other ► select the correct language ► press the right display key

Select country

Select the country where you are using the phone. Your selection is used for country-specific defaults.

- ► **Settings** ► **OK** ► **Telephony** ► **OK** ► **Country** ► **OK** ► select the country ► **Select** (= selected)

Display and keypad

Screensaver

A digital or analogue clock and a range of pictures can be selected to be displayed as a screensaver when in idle status.

- ► **Settings** ► **OK** ► **Display + Keypad** ► **OK** ► **Screensaver** ► **Edit** (= on) . . . then

- | | |
|---------------------|--|
| Switch on/off: | • Activation: select On or Off |
| Select screensaver: | • Selection ► select a screensaver (Digital Clock / Analog Clock / Slideshow / <Pictures>) |
| View screensaver: | • View |
| Save selection: | • Save |

The screensaver is activated approx. 10 seconds after the display has changed to idle status.



All pictures from the Screensaver folder of the Resource Directory are available for selection.

End screensaver

- Press the **End** call key briefly . . . the display changes to idle status

Large font

Show text and icons in call lists and in the directory in a larger size in order to improve legibility. Only one entry is shown in the display and names are abbreviated if necessary.

- ▶ ▶ **Settings** ▶ **OK** ▶ **Display + Keypad** ▶ **OK** ▶ **Large Font** ▶ **Change** = on)

Colour scheme

You can choose from a range of colour combinations for the display.

- ▶ ▶ **Settings** ▶ **OK** ▶ **Display + Keypad** ▶ **OK** ▶ **Colour Schemes** ▶ **OK** ▶ select the desired colour scheme ▶ **Select** = selected)

Display backlight

The display backlight always illuminates when the handset is taken out of the base station/ charging cradle or when a key is pressed. Any digit keys that are pressed appear on the display for pre-dialling.

Switch the display backlight on/off when in idle status:

- ▶ ▶ **Settings** ▶ **OK** ▶ **Display + Keypad** ▶ **OK** ▶ **Display Backlight** ▶ **OK** ▶ select when the setting is applied (In Charger / Out of Charger / In Talk State) ▶ select in each case with **On or Off** ▶ **Save**



The handset's standby time may be significantly reduced if the display backlight is switched on.

Feature key

You can change the function on the feature key.

- ▶ ▶ **Settings** ▶ **OK** ▶ **Display + Keypad** ▶ **OK** ▶ **Display Backlight** ▶ **OK** . . . then

Switch on/off:

- Activation ▶ select **On** or **Off**

Choose the function:

- Function ▶ select the function: Quick dial, Alarm key, Send key

Depending on the function, you have the following options:

Keypad locked:

- Select Key inactive or Key active

Via:

- Select **Earphone** or **Handsfree**

Call to:

- enter the number or choose from directory

Feature Key PIN:

- enter the PIN
- **Save**

You have additional options for the alarm key function:

Short key press:

- select **On** or **Off**

Long key press:

- select **On** or **Off**

Alarm delay:

- select the delay: Off / 5 sec. / 10 sec. / 15 sec. / 30 sec.
- select the melody
- select the volume







Keypad illumination

The keypad has 5 levels of brightness to choose from.

-  ►   **Settings** ►  ►  **Display + Keypad** ►  ►  **Key Illumination** ►  ►  select Intensity (1 - 5) ►  **Save**

Activating/deactivating automatic keypad lock

Automatically lock the keypad when the handset has been in idle status for around 15 seconds.

-  ►   **Settings** ►  ►  **Display + Keypad** ►  ►  **Auto Keypadlock** ► **Change** = on)

Tones and signals



Call volume

You can set the volume of the earpiece, handsfree function and headset on 5 levels independently of each other.







Changes are only saved permanently in Profile Personal.

During a conversation

-  **Handset Volume** ►  select volume ►  **Save** . . . the setting is saved

In idle status

-  **Handset Volume** ►  select what the setting is to apply for (Earpiece / Speaker / Corded headset) ►  select the volume ►  **Save** . . . The setting is saved

or

-  ►   **Audio Settings** ►  ► **Handset Volume** ►  ►  select what the setting is to apply for (**Earpiece / Speaker / Corded headset**) ►  set the volume ►  **Save**

Automatic volume control



Crescendo is not set for the ringtone volume (→ p. 43).

The phone is able to automatically adjust the volume of the receiver and ringtone to the ambient volume. Here you can set the sensitivity with which the phone reacts to changes in noise level (Very High, High, Medium, Low, Very Low).

- ► **Audio Settings** ► **OK** ► **Smart Volume** ► **OK** ► **Earpiece Volume / Ringtone Volume** ► **Edit**

- Enable/disable: • Activation: select **On** or **Off**
- Adjust the sensor: • **Sensitivity** ► adjust the sensor sensitivity
- Save: • **Save**

Headset – volume correction

Change the call volume for the wired headset. In addition to the standard settings for the call volumes, here you can compensate the audio setting characteristics of your headset.

- ► **Audio Settings** ► **OK** ► **Corded Hdset Boost** ► set the volume ► **Save**

Microphone sensitivity

Adjust the sensitivity of the microphone for the receiver or wired headset. This gives you improved acoustics in loud environments and when there are echoes.

- ► **Audio Settings** ► **OK** ► **Mic Sensitivity** ► **OK** ► select what the setting applies for (**Earpiece / Corded headset**) ► adjust the sensitivity ► **Save**

Earpiece and handsfree profile

Select a profile for the earpiece and handsfree mode in order to adapt the telephone as much as possible to the surroundings. Check which is the most comfortable profile for you and your caller.

- ► **Audio Settings** ► **OK** ► **Acoustic Profiles** ► **Earpiece Tones / Handsfree Profiles** ► **OK** ► select profile ► Select = selected)

Earpiece Tones: High frequency or Low frequency (default setting)

Handsfree Profiles: Standard (default setting) or Reduced Echo

Ringtones

Ringtone volume

Set different ringtone volumes for internal and external calls, and other connections configured (group calls, intercom, emergency calls) or set the same ringtone volume for all external calls.

- ► **Audio Settings** ► **OK** ► **Ringtones (Handset)** ► **OK** ► **Volume** ► **OK** ► Select **Internal calls** and appointments or **External calls** ► Set the volume on 5 levels or Crescendo (increasing volume) ► **Save**



Changes are only saved permanently in Profile Personal.

Ringtone melody

Set different ringtones for internal and external calls, or other connections configured (group calls, intercom, emergency calls) or set the same ringtone for all external calls.

- ► **Audio Settings** ► **OK** ► **Ringtones (Handset)** ► **OK** ► **Melodies** ► **OK** ► Select **Internal Calls** or **External calls** ► Select the ringtone/melody in each case ► **Save**

Switching the ringtone on/off

Switching the ringtone off permanently

- Press and **hold** ► select **Profile Silent** . . . The following icon appears in the status bar:

or: Enable "Do not disturb"

- ► **Audio Settings** ► **OK** ► **Do Not Disturb** ► **Change** (= enabled)

Switching the ringtone on permanently

- Press and hold ► select **Profile Loud** or **Profile Personal**

Switching the ringtone off for the current call

- Silence or press the End call key

Switching the alert tone (beep) on/off

Switch on an alert tone (beep) instead of the ringtone:

- Press and **hold** ► select **Profile Silent** ► Press **Beep** within 3 seconds . . . The following is shown in the status bar:

Switching off the alert tone: ► Press and **hold** or press the **Star** key to change profile

Switching advisory tones on/off

The handset notifies acoustically about different activities and statuses. These advisory tones can be switched on/off independently of each other.

- ► **Audio Settings** ► **OK** ► **Advisory Tones** ► **OK** ... then

Tone when keys are pressed:

- **Key Tones:** select **On** or **Off**

Confirmation/error tone after making entries, advisory tone when a new message has been received:

- **Confirmation** ► select **On** or **Off**

Warning tone when there are fewer than 10 minutes of talktime remaining (every 60 seconds):

- **Battery** ► select **On** or **Off**

Warning tone when the handset is moved out of range of the base station:

- **Out of Range:** select **On** or **Off**

Save settings:

- **Save**
-

Auto answer

When Auto answer is enabled, the handset accepts an incoming call as soon as it is removed from the charging cradle.

- ► **Settings** ► **OK** ► **Telephony** ► **OK** ► **Auto Answer** ► **Change**
(= activated)

Regardless of the Auto Answer setting, the connection ends as soon as you place the handset back in the charging cradle. Exception: Press and **hold** the handsfree key for a further 2 seconds while placing the handset in the charging cradle.

Emergency numbers

You can enter up to three phone numbers as emergency numbers - that you can also dial when the keypad lock is PIN-protected.

- ► **Settings** ► **OK** ► **Telephony** ► **OK** ► **Emergency Numbers** ► **OK** ► select an entry (--- = empty entry) ► **Change** ► enter the name for the emergency number ► ► enter the emergency number ► **Save**

Delete entry: ► **<C** delete the name and phone number ► **Save**



Fast access to numbers and functions

Assigning a number to digit keys (quick dial)

It is possible to assign a number from the directory to the keys to .



A number has not been assigned to the digit key.

- Press and hold the digit key
- or
- Briefly press the digit key ► Press the display key **QuickDial** . . . the directory opens.
 - use  to select an entry ► **OK** ► use  to select a number if necessary ► **OK** . . . the entry is saved to the digit key



If the entry in the directory is deleted later, this will not affect the assignment of the digit key.

Dialling a number

- Press and **hold** the digit key . . . the number is dialled immediately
- or
- **Briefly** press the digit key . . . the number/name (possibly in abbreviated form) is shown on the left display key ► press the display key . . . the number is dialled

Changing the digit key assignment

- **Briefly** press the digit key ► **Change** . . . the directory is opened . . . possible options:
 - Change the assignment:
 -  select an entry ► **OK** ► select a number if required ► **OK**
 - Delete the assignment:
 - **Clear Key**

Assigning display keys / Changing assignments

The left and right display keys have a function preset by default when in idle mode. The key can be re-assigned.

- Press and hold the left or right display key in idle status . . . the list of possible key assignments is opened ►  select the function ► **OK** . . . The assignment of the display key is changed

Possible functions: **Call Lists, INT, QuickDial, Timer, Alarm Clock, Calendar, Bluetooth, Redial, Do Not Disturb, Handset Directory, R Function**

Starting a function

With the telephone in idle status: ► **Briefly** press . . . the assigned function is executed

Changing the handset PIN

The handset is protected against unauthorised use by a PIN. The handset PIN must be entered e. g. when switching off the keypad lock.

Change the handset's 4-digit PIN (default setting: 0000):





-  ►  ►  **Settings** ► **OK** ►  **System** ► **OK** ►  **Handset PIN** ► **OK** ►  enter the current PIN ► **OK** ►  enter the new handset PIN ► **OK**



If the correct handset PIN is not entered after 5 failed attempts, a 15-second timer is started. Every failed attempt thereafter doubles the timer (up to a maximum delay of 8 hours between PIN entry attempts).

Resetting a handset

Reset any individual settings and changes that you have made.

-  ►   **Settings** ► **OK** ►  **System** ► **OK** ►  **Handset Reset** ► **OK** ► Yes ... the handset's settings are reset







The following settings are not affected by a reset

- Registration of the handset to the base station
- Date and time
- Directory entries and call lists

Resetting the handset to the default settings

Reset all settings and personal information.

-  ►   **Settings** ► **OK** ►  **System** ► **OK** ►  **Erase Handset** ► **OK** ►  enter the current PIN ► **OK**

All user information, lists, the directory and the handset registration with the base are erased. The Registration wizard is started.

Appendix

Manufacturer's advice

Disposal

- Batteries should not be disposed of in general household waste. Observe the local waste disposal regulations, details of which can be obtained from your local authority.
- All electrical and electronic products should be disposed of separately from the municipal waste stream via designated collection facilities appointed by the government or the local authorities.



- This crossed-out wheeled bin symbol on the product means the product is covered by the European Directive 2012/19/EU.
 - UK: The Waste Electrical and Electronic Equipment Regulations 2013.
 - The correct disposal and separate collection of your old appliance will help prevent potential negative consequences for the environment and human health. It is a precondition for reuse and recycling of used electrical and electronic equipment.
- For more detailed information about disposal of your old appliance, please contact your local council refuse centre or the original supplier of the product.

Care

- Wipe the device with a **damp** cloth or an antistatic cloth. Do not use solvents or micro-fibre cloths.
 - **Never** use a dry cloth; this can cause static.
 - In rare cases, contact with chemical substances can cause changes to the device's exterior. Due to the wide variety of chemical products available on the market, it was not possible to test all substances.
 - Impairments in high-gloss finishes can be carefully removed using display polishes for mobile phones.
-

Contact with liquid

- If the device comes into contact with liquid:
 1. Unplug all cables from the device.
 2. Remove the batteries and leave the battery compartment open.
 3. Allow the liquid to drain from the device.
 4. Pat all parts dry.
 5. Place the device in a dry, warm place **for at least 72 hours** (not in a microwave, oven etc.) with the battery compartment open and the keypad facing down (if applicable).
 6. Do not switch on the device again until it is completely dry.

When it has fully dried out, you will normally be able to use it again.

Technical data

Battery

Technology:	2x AAA NiMH
Voltage:	1.2 V
Capacity:	750 mAh

Handset operating times/charging times

The operating time of your OpenScape DECT Phone SL7 depends on the capacity of the battery, its age and the way it is used. (All times are maximum possible times.)

Standby time (hours)	320
Talktime (hours)	12
Operating time with 1.5 hours of calls per day (hours)	130
Charging time in charging cradle (hours)	5,5
Charging time in charging cradle up to 80% (hours)	2

No display lighting when the phone is idle and during a call

Power consumption of the handset in the charging cradle

When charging:	approx. 1.50 W
To maintain the charge status:	approx. 0.50 W

General specifications

DECT standard	Supported
GAP standard	Supported
No. of channels	60 duplex channels
Radio frequency range	1880-1900 MHz
Duplex mode	Time division multiplexing, 10 ms frame length
Repetition frequency of the transmission pulse	100 Hz
Duration of the transmission pulse	370 µs
Channel grid	1728 kHz
Bit rate	1152 kbit/s
Modulation	GFSK
Language code	32 kbit/s
Transmission power	10 mW average power per channel, 250 mW pulse power
Range	Up to 50 m indoors, up to 300 m outdoors

Base station power supply	230 V ~/50 Hz
Environmental conditions for operation	+5 °C to +45 °C; 20% to 75% relative humidity
Dialling mode	DTMF (tone dialling)

Bluetooth

Version	5.1
Radio frequency range	2402-2480 MHz
Transmission power	4 mW pulse power

Power adapter for the handset

Manufacturer	Salom Electric (Xiamen) Co. Ltd. Commercial registration number: 91350200612003878C 31 Building, Huli Industrial District, Xiamen, Fujian 361006, P.R. China
Model identifier	C812 / C813
Input voltage	230 V
Input AC frequency	50 Hz
Output voltage	5 V (USB-C)
Output current	1 A
Output power	5 W
Average active efficiency	> 73.62 %
No-load power consumption	< 0.10 W

Character charts

The character set used on the handset is dependent on the language set.

Standard characters

Press the relevant key the number of times indicated.

Technical data















	1x	2x	3x	4x	5x	6x	7x	8x	9x	10x
1	1									
2	a	b	c	2	ä	á	à	â	ã	ç
3	d	e	f	3	ë	é	è	ê		
4	g	h	i	4	ğ	í	ì	î	ı	
5	j	k	l	5						
6	m	n	o	6	ö	ñ	ó	ò	ô	õ
7	p	q	r	s	7	ß				
8	t	u	v	8	ü	ú	ù	û		
9	w	x	y	z	9	ÿ	ý	æ	ø	å
0	␣ ¹⁾	.	,	?	!	← ²⁾	0			

- 1) Space
- 2) Line break





Display icons

The following icons are displayed depending on the settings and the operating status of your telephone.









Icons in the status bar

Icon	Meaning
	Signal strength (No Radiation off) 1% -100%
	white, if Maximum Range on; green, if Maximum Range off
	Red: no connection to the base station
	No Radiation activated: white, if Maximum Range on; green, if Maximum Range off
	Profile Silent activated (Ringtone switched off)
	"Beep" ringtone activated
	Keypad lock activated
	Bluetooth enabled
	Using the handset as a Bluetooth beacon
	Headset / hearing aid connected via Bluetooth
	Data device connected via Bluetooth
	"Do not disturb" enabled
	Battery charge status, depending on the bar length 0 – 100 %
	white: over 11%; red: below 11%; flashes red: Battery almost empty (approx. 5 minutes of talktime left)
	Battery is charging (current charge status): 0 % - 100 %











Display key icons

Icon	Meaning
	Last number redial
	Delete text
	Open the directory
	Copy number to the directory

Display icons to indicate . . .





















Icon	Meaning
	External call
	Internal call
	Establishing a call (outgoing call)
	Connection established
	No connection established/connection terminated
	Reminder for appointment
	Reminder for anniversary
	Alarm call
	Countdown timer

Other display icons

Icon	Meaning
	Missed calls
	Missed appointments
	New voice messages
	Alarm clock is activated, display with alarm time
	Timer switched on, display with countdown
	Action complete (green)
	Action failed (red)
	Information
	(Security) prompt
	Please wait ...

Display icons

Alarm icons

Icon	Meaning
	Bomb alarm
	Robbery alarm
	Chemical accident
	Evacuation
	Explosion
	Fire
	Flood
	Heart attack
	Risk of poisoning
	High volume
	Machine failure
	Personal accident
	Medical assistance required
	Medical emergency
	Nurse/carer requested
	Power failure
	Radiation/radioactivity
	Firearm use
	Poisonous gases
	Exposure to violence

Accessing system functions

The system functions can be accessed via the Service menu.

Structure of the Service menu



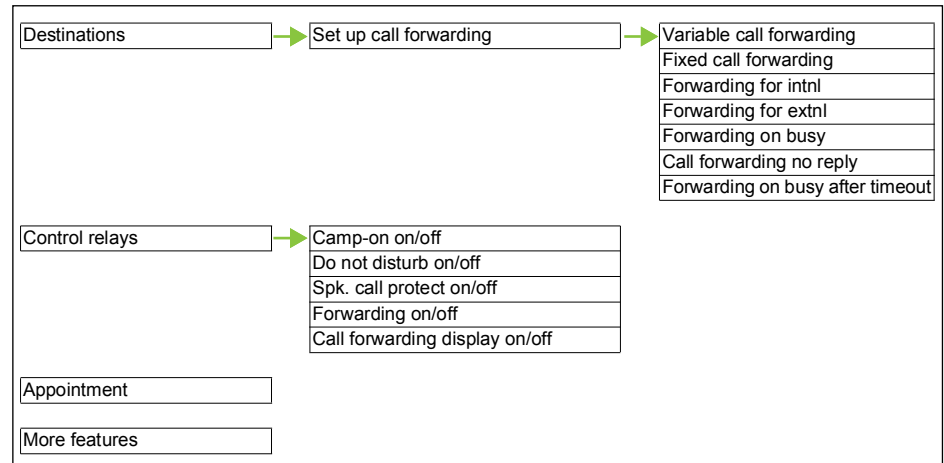

Note:

Not all menu options are displayed depending on the system configuration.













Using the Service menu

The Service menu can be used both by means of the control key and the display keys.

Control key	Function	Alternative Usage
	Open Service menu or One level higher	Left display key
	One level lower During a call: Adjust call volume and open local phonebook	Right display key
	Scroll Previous	-
	Scroll Next	-
	Confirm your selection	-

Operation using the control key is shown below.

Example: Selecting the "second call" feature

- | | |
|---|--|
|  | Open the Service menu. |
|   BASIC SERVICE ...  | Select and confirm the basic service. The Service menu is displayed. |
|   Feature settings  | Select the menu item and confirm (example). |
|   Camp-on  | Select the menu item and confirm (example). |

Making calls to multiple parties

Consultation

You interrupt your call to consult with a user (including external users) and then resume the original call.

You are conducting a call.

Activating and conducting an inquiry/consultation call

Activate inquiry. The current call is placed "on hold", so that the first user waits. Enter the phone number for the consultation call.

The number is dialed. The station answers. The consultation starts.

The second user is busy or does not answer

During the consultation you can:

- Book a callback → page 86,
- Activate call waiting → page 41 or
- Busy override → page 42.

Ending a consultation call and returning to the waiting call

Either:

  TO WAIT. CALL 

If the consultation call/inquiry function was activated but a number was not yet entered: Select the menu item and confirm.

  RETURN 

Select the menu item and confirm.

You are reconnected with the first party. The second call party hears the busy tone and hangs up.

Or   TO WAIT. CALL 

The second user hangs up. By pressing "TO WAIT. CALL ", you are reconnected

with the first party again.

You can also:

- Toggle between the partners → page 44,
- Set up a conference → page 45 or
- Transfer the waiting partner to the second partner → page 43.

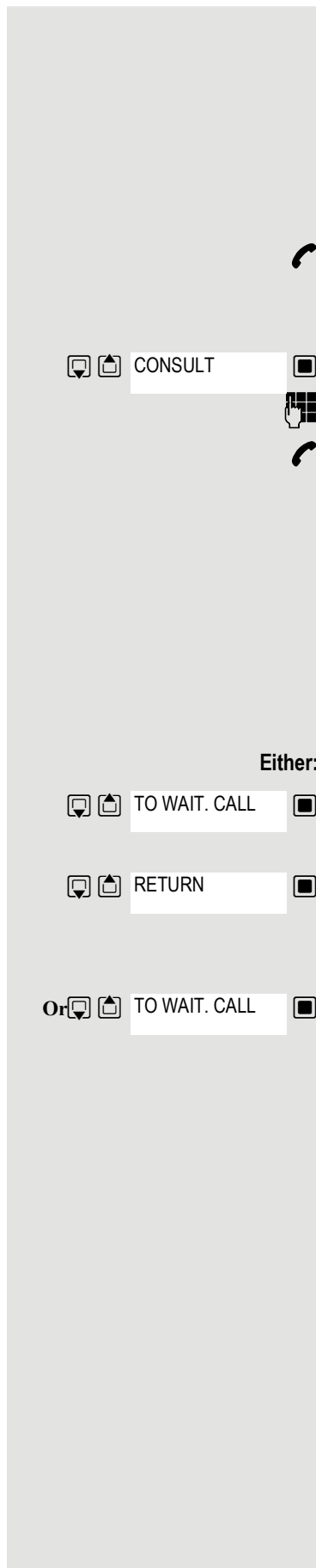

Call waiting

You need to speak to a user in your communications system urgently, even though this user's line is busy. You can send a call waiting signal during the call to let the user know you want to talk to him or her. The user either answers immediately or you will be automatically connected when he or she has finished his call.

This function is only available if it has been configured by the service engineer.

The user is busy. You want to use call waiting.

Select the menu item, confirm and wait briefly.



Note:

To camp on, you must have the appropriate class of service.

Camp-on is not possible if the called party is protected by the camp-on security function.

You receive a call waiting signal (second call)

You are still available to other callers, even though you are on the telephone. The call waiting signal informs you of the second call while you are conducting a call. You can answer this call without ending the first call.

You are on a call and hear a call waiting signal.

If you want to answer the second call, you can either place the first call on hold (the first caller waits) or end the first call.

Placing the first call on hold and answering the second call

Confirm to accept the second call.

Talk to the second caller. The first caller waits. His or her call is on hold. You can now:

- Toggle between the two callers → page 44 or
- Set up a conference → page 45.

Ending the second call

 Press the End call key. Your handset rings.

 Press the Talk key to talk to the first caller again.

Ending the first call

 Press the End call key. The first call is ended. Your phone rings.

 Press the Talk key and answer the second call.



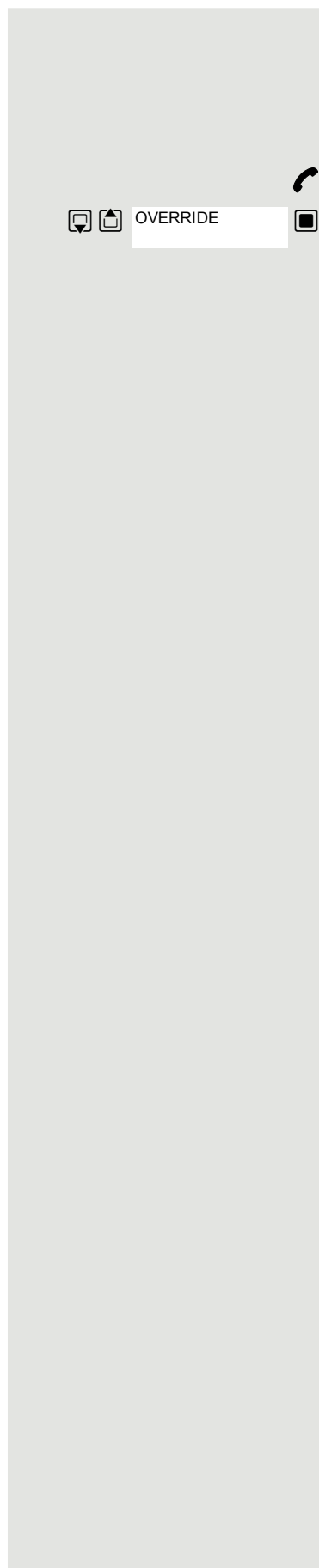

Override

You need to speak to an internal user urgently, even though his or her line is busy. The "Override" function allows you to interrupt the ongoing call to pass on a message.

The user is busy.

Select the menu item and confirm.

Both your colleague and their call partner hear a warning tone.

You can now start talking.

 **Note:**

To override, you must have the appropriate class of service.

Override is not possible if the called party is protected by the Privacy function.

Transferring a call

If the person you are speaking to wishes to be forwarded to one of your colleagues you can transfer the call.

Transferring the call with prior announcement:

Select the menu item and confirm.

Enter the number of the party to whom you want to transfer the call.

Announce the call partner.

Press the End call key. The person you were speaking to is now connected to the desired party.

Transferring the call without prior announcement:

Select the menu item and confirm.

Enter the number of the party to whom you want to transfer the call.

Press the End call key.

Note:

If a connection is not set up between the other two parties within 40 seconds, you will be called again. You are reconnected with the first party.

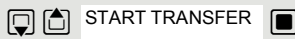
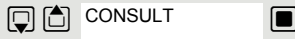

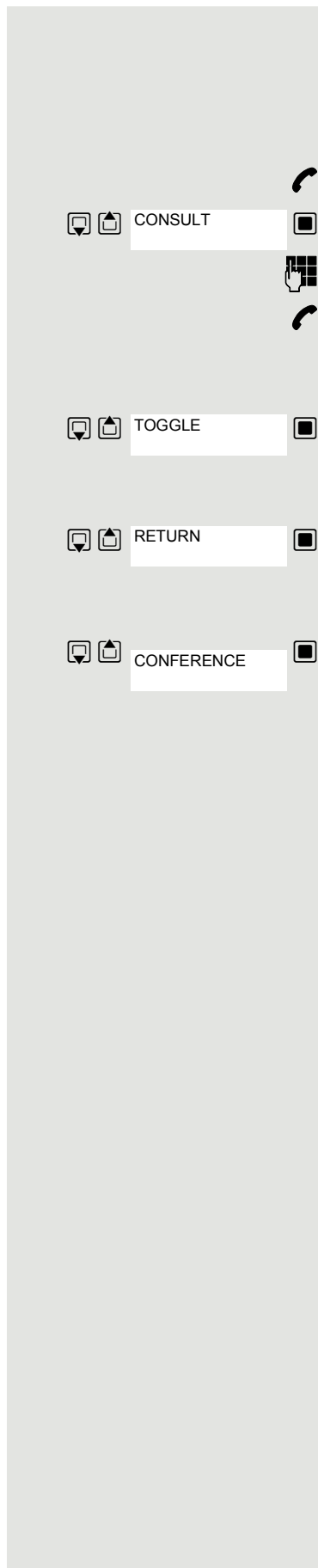

Toggling (switching between calls)

The Toggle function allows you to switch between two users without allowing them to speak to each other directly. The two users can be either external or internal users. You can also start a conference.

You are conducting a call.

Press the display key. The current call is placed "on hold", the user waits.

Enter the phone number of the second user.

The second user answers.

Switching to the caller on hold

Press the display key to switch between the two calls.

Ending the present call – returning to the other call

Select the menu item and confirm.

Setting up a three-way conference

Select the menu item and confirm.

An alerting tone advises you that a conference call is now in progress between all three parties.

Conducting a conference

In a system-assisted conference you can include up to 8 internal and external users. Users with system telephones can perform or use all the following functions simultaneously. ISDN telephones and external stations are passive users—they can only be included in an existing conference.

You can include parties and conferences from a remote system in your conference. The remote parties can set up a conference of their own and extend it. The members of this conference are included in your current conference – but they cannot perform or use the following functions.

The following functions are supported for all conference participants with a system telephone:

- Setting up a conference when calling a user or receiving a call or making a consultation call or receiving a second call.
- Accepting a waiting call and including the caller in the conference.
- Toggling between the conference and a consultation call or second call.
- Conducting a consultation call during a conference and connecting it to the conference.
- Interconnecting conference members from two independent conferences via a remote network.
- Putting the conference on hold if line keys are installed.
- Obtaining an overview of all conference participants.
- Transferring a conference to a new party.

The functions listed can be performed by all conference participants at the same time.

Setting up a conference

You can set up a conference from any of the following types of connection:

- Single call
- Consultation call
- Second call

Initiating a conference from a single call

You want to set up a conference.

You are conducting a call.

Select the menu item and confirm.

Call another user.

Announce that a conference is to be set up.

Select the menu item and confirm. You will briefly see the message: "1 is your position".

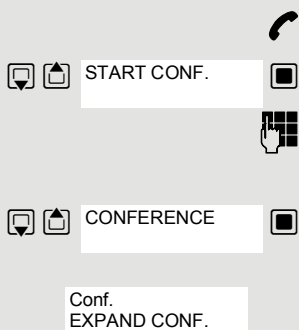

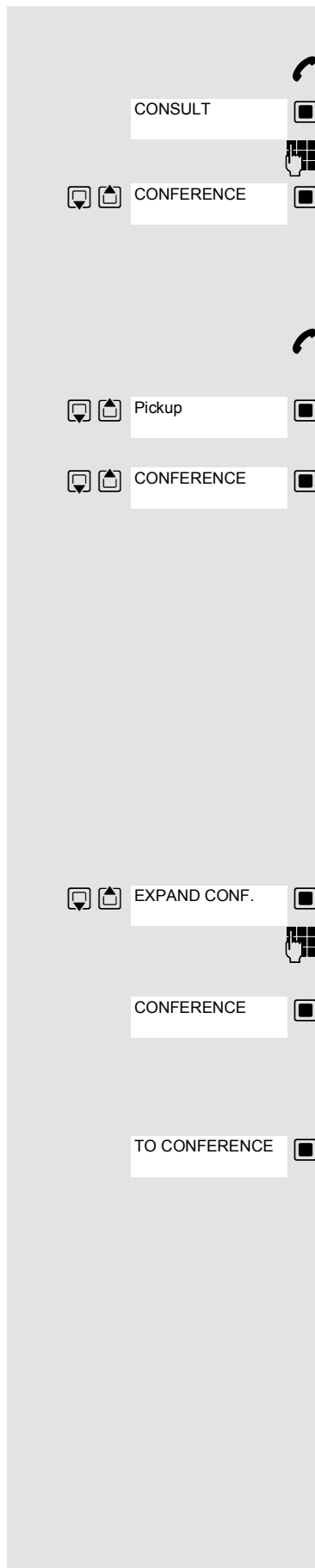

Setting up a conference from a consultation call

You are connected to one user and you call a second user.

Confirm the option shown.

Call another user. The second user answers, you announce the conference.

Select the menu item and confirm. You will briefly see the message: "1 is your position".

Setting up a conference from a second call

You are connected to one user and receive a second call, which is signaled by an alerting tone.

Select and confirm the option shown. You are connected to the second caller. The other party is placed on hold.

Select the menu item and confirm. You will briefly see the message: "1 is your position". All members are connected in a conference call.

Expanding a conference

Any member of the system conference can expand the conference by:

- calling another user and adding this person to the conference,
- connecting a party from a consultation call to the conference, or
- accepting a second call and adding the caller to the conference.

Calling another specific party and connecting them

You intend calling another party and connecting them to the conference.

Select the menu item and confirm.

Call the new party.

Announce that a conference is to be set up.

Confirm the option shown.

The party is added to the conference.

If the new user does not answer:

Confirm the option shown.

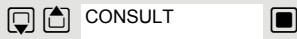

Either:

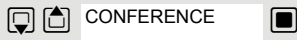

Or:



Or:



Expanding the conference from a consultation call

You wish to make a consultation call during the conference.

Select the menu item and confirm. The conference is placed on hold.

Call a party. Make the consultation call.

Select the menu item and confirm to add the user from the consultation call to the conference.

Toggle between the conference and the consultation call.

Select the menu item and confirm to release the consultation call and return to the conference.

Accepting a second call and adding it to the conference

If you receive a second call during the conference (the second call function is activated), you can add this user to the conference.

You hear an alerting tone.

Select and confirm the option shown. You are connected to the second caller. The conference is placed on hold.

Select and confirm to add the second caller to the conference.

Toggle between the conference and the second call.

Select and confirm to release the second call and return to the conference.

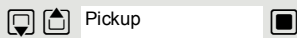

Either:

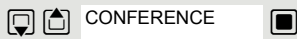

Or:



Or:



Transferring the conference

Any party can transfer the conference to a third party whom he or she has called by using the consultation or "expand conference" function. This party is not yet a participant in the conference. The conference cannot be transferred to a second call.

You are taking part in a conference

Select and confirm the option shown. The conference is placed on hold.

Call a party.

Select and confirm the option shown.

Call a party.

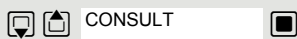

Either:



Or:



Or:

  CONF. TRANSFER 

Announce that you are transferring the conference

Select and confirm the option shown.

You are disconnected from the conference.

Press the End call key.



During the conference

You are taking part in a conference with 3 to 8 members and you wish to know about the other members or to disconnect a certain member or to disconnect the last member added to the conference.

Viewing member information and disconnecting members

  VIEW MEMBERS? 

Select and confirm the option shown.

Phone no. Party 1
NEXT CONF PTY?

The display shows the phone number and possibly the name of the conference member with the lowest member number.

Either:

 NEXT CONF PTY? 



Confirm to display the next member.

Or:

  STOP VIEWING? 

Select and confirm to end the display.

Or:

  RELEASE PARTY? 

Select and confirm to disconnect this party from the conference. If there were only three members, the conference is now ended.

Disconnecting the last member added

You wish to disconnect the last party added to the conference.

  REM LAST PTY? 

Select and confirm the option shown. The last member added is disconnected. If there were only three members, the conference is now ended.

Using the second call feature

If you are expecting an important call, you should activate the camp-on function. A second call will then be signaled while a call is in progress. You can accept or ignore the second call.



Note:

A second call is not signaled on the Bluetooth headset.

Activating and deactivating second call

Open the system menu.

Select and confirm the basic service.

Either:

2 ABC 1 CD

Enter the service code.

Or:

Feature settings

Select the menu item and confirm.

Camp-on

Select the menu item and confirm.

then:

Activate

Activating or deactivating

Confirm one of the two displays.

Deactivate

Accepting a second call

Prerequisite: You are making a call. The camp-on function is activated.

You will hear an alerting tone. The caller hears the ring tone as if you were "free".

Select and confirm the option shown. You are connected to the second caller.

The first party is placed on hold.

Ending the second call, resuming the first call:

Replace the handset and lift it again.

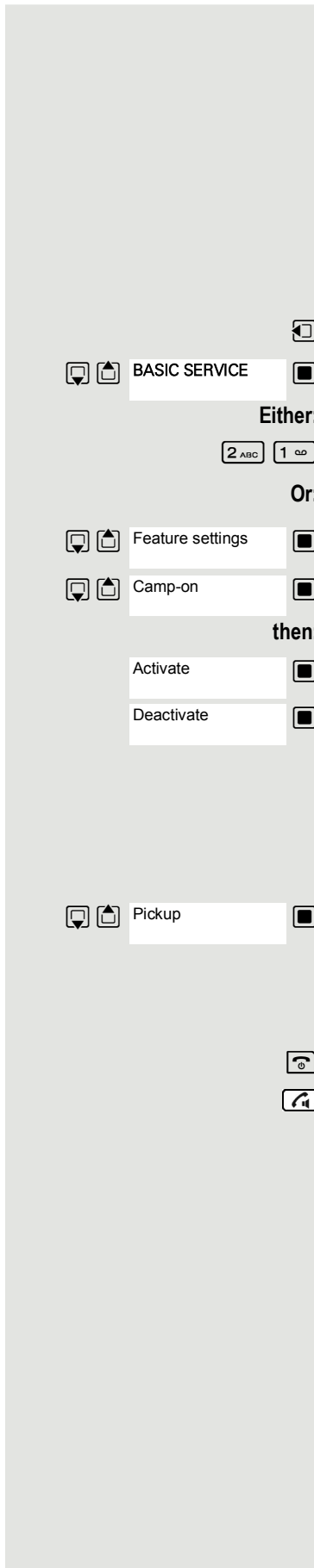

Caller list

Callers who have tried to reach during your absence are saved in the "Caller list". Callback requests → page 86 are also recorded here.



Note:

If the "local call list" was allocated to the handset in the system, then please use the description on → page 22.

Retrieving the caller list

An advisory message appears and the message key flashes when one or more information messages or voicemails have been received for you.

Either:



Press the message key.

Or:



Open the system menu.



QUERY NO.



Select the menu item and confirm.

46068
34101 ✓



The phone number or associated names are displayed. Phone numbers that have been viewed are ticked.

Press to view the list of phone numbers (names). Phone numbers (names) that have already been viewed are ticked.

Calling back a caller on the list



Press to select the required phone number (name).



Press to display the menu selection.



DIAL



Select and confirm the option shown.
The station will be called.

Deleting a caller from the list



Press to select the required phone number (name).



Press to display the menu selection.



DELETE



Select and confirm the option shown. The entry is deleted and the missed calls list is displayed again.

Exiting the missed calls list



Press to move up to the next or a higher level of the menu

Or:



Press the End call key to return to the idle menu.

Central directories (group directory)

You can save your private phonebook that is saved on your handset to a central server and add group phonebooks that are saved on this server to your private phonebook.

To protect phone numbers in your private phonebook from being modified when a group phonebook is added, we recommend first saving your private phonebook using the function "Send List" → page 71.

If the number of group directory entries exceeds the volume of memory available in your private phonebook, the transfer operation terminates as soon as the memory capacity limit is reached.

Open the system menu.



Select and confirm the phonebook.

Either:



Deleting the private phonebook

Select the menu item and confirm.

The following message appears:
PHONEBOOK DELETED

Or:

Loading the private phonebook

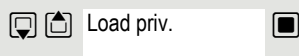

Select the menu item and confirm.

Or:

Loading the group directory

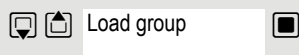

Select the menu item and confirm.



Select and confirm the group directory.

Press the End call key to end the operation.

Sending and receiving an entry or list of entries

You can send either an individual entry or the entire list to the communications system. This list can be received by the communications system and returned. Furthermore, it is also possible to load group directories.

Restrictions when copying using the communications system

The entries in the handset's phonebook are stored in vCard format. The communications system, however, uses another format. This can cause loss of phonebook entry information. The phone numbers are not affected.

Sending a list/entry

Open the phonebook.

Select the entry you want.

Press the display key.

Select the menu item and confirm.

Select the menu item and confirm.

Select the menu item and confirm.

Enter phone number 00 and confirm.

Select this option for additional entries.

Loading a list from the communications system

Prerequisite: You sent an entry or list to the communications system by dialing the phone number 00.

Press the INT key.

Select the menu item and confirm.

Select the menu item and confirm.

Select the menu item and confirm.

Press the End call key once. You will receive a call from the system and the transfer starts once you answer this call.

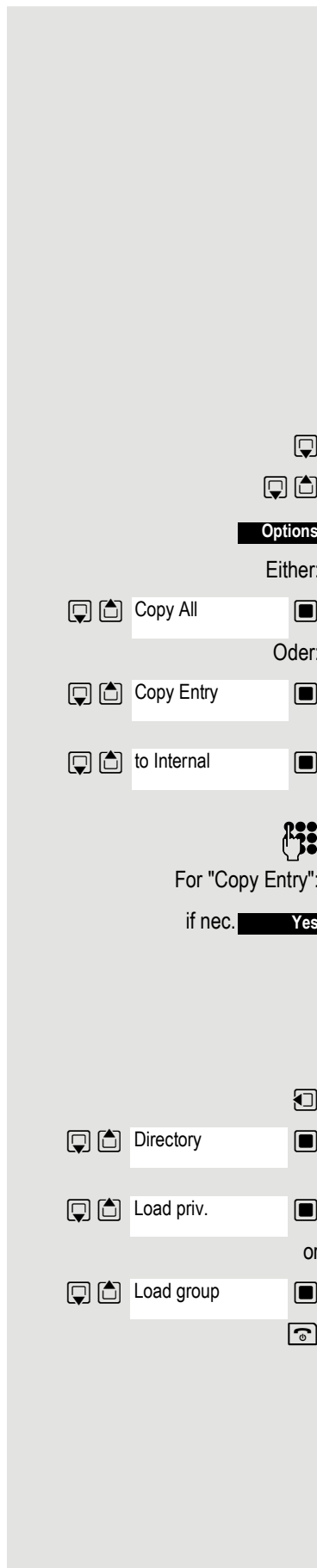

Deleting a list in the communications system

Prerequisite: A currently unused list or entry is saved on the communications system.

If the handset with phone number 00 was used to send the list or entry to the communications system, any handset can be used to delete this list or entry.

Press the INT key.

Select the menu item and confirm.

Select the menu item and confirm. The handset starts to delete the list/entry.

Press the End call key to end the operation.

Loading the group directory

A group directory has to be created in the communications system by the service engineer and assigned to the authorized users.

Press the INT key.

Select the menu item and confirm.

Select the menu item and confirm.

Select and confirm the group directory.

Press the End call key to end the operation.

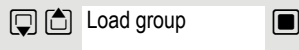
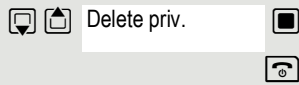

Call forwarding

Using call forwarding

You can program two types of call forwarding:

- Fixed call forwarding and
- Variable call forwarding.

For fixed call forwarding, you program a forwarding destination that will remain valid until you change or delete it. You can activate and deactivate this forwarding function.

For variable call forwarding, you can choose between six different forwarding types:

- Variable forwarding (unconditional forwarding)
- Forwarding for internal
- Forwarding for external
- Forwarding on busy
- Call forwarding no reply
- Forwarding on busy/after timeout

Call forwarding is activated when a forwarding destination is programmed.

When the phone is idle, active forwarding instructions are shown on the display, for instance `Forwarding: 47110 to 47200`.

47110 --> 47200

You can use codes to activate and deactivate call forwarding → page 79.





**Note:**

The function must be approved for your communications system.

Fixed forwarding





If you have programmed a forwarding destination for fixed forwarding, you can activate and deactivate the forwarding facility in the Service menu. The programmed forwarding destination remains valid until you change or delete it.

Programming and activating a forwarding destination

- | | | |
|---|----------------|---|
|  | | Open the system menu. |
|  | BASIC SERVICE | Select and confirm the basic service. |
|  | DESTINATIONS | Select the menu item and confirm. |
| | FORWARD | Confirm the option shown. "Variable forwarding" is displayed. |
| | NEXT | Confirm the option shown. "Fixed forwarding" is displayed. If call forwarding has already been programmed, the forwarding destination is displayed. |
|  | ENTER DESTIN.: | Select and confirm the option shown. |
|  | | Enter the phone number for the forwarding destination. Any destination previously saved will be overwritten. |
| | SAVE | Confirm when the complete number has been entered. Call forwarding to the programmed destination is active. |

Activating and deactivating fixed forwarding

You can only activate and deactivate fixed forwarding if a destination number has been programmed.

- | | | |
|---|---------------|--|
|  | | Open the system menu. |
|  | BASIC SERVICE | Select and confirm the basic service. |
|  | DESTINATIONS | Select the menu item and confirm. |
| | FORWARD | Confirm the option shown. "Variable forwarding" is displayed. |
| | NEXT | Confirm the option shown. |
| | FWD-FIXED off | The display shows "Fixed forwarding". |
|  | Deactivate | Select the menu item and confirm. Fixed forwarding is deactivated. |
| | FWD-FIXED off | The display shows "Fixed forwarding". |
|  | Activate | Select the menu item and confirm. Fixed forwarding is activated. |

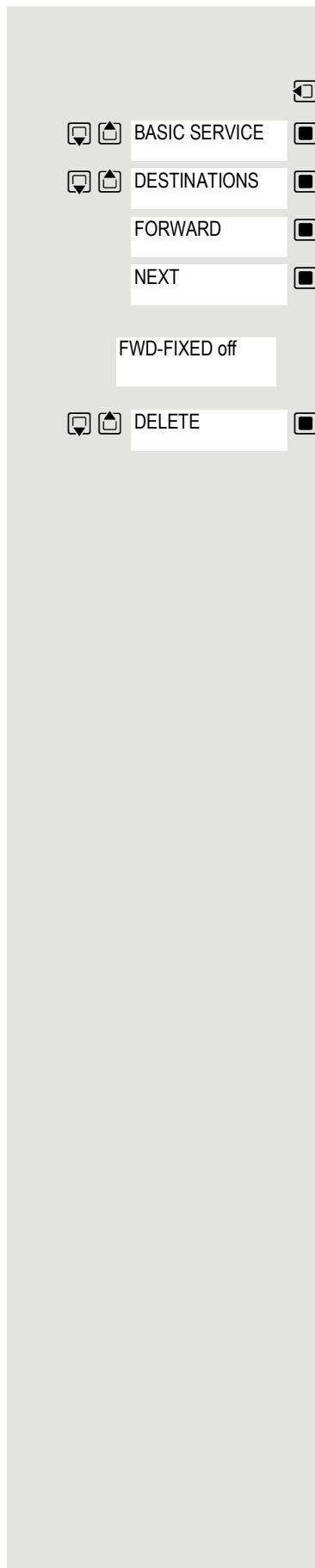

Deleting the destination for fixed forwarding

You can delete the destination for fixed forwarding.

Open the system menu.

Select and confirm the basic service.

Select the menu item and confirm.

Confirm the option shown. "Variable forwarding" is displayed.

Confirm the option shown. The display shows "Fixed forwarding" and the forwarding destination.

The display shows "Fixed forwarding" and the forwarding destination when forwarding is activated.

Select and confirm the option shown. The forwarding destination is deleted. If fixed forwarding was activated it is now deactivated.

Variable forwarding

For variable forwarding you can choose between six different call forwarding types:

- Variable forwarding (unconditional forwarding)
- Forwarding for internal
- Forwarding for external
- Forwarding on busy
- Call forwarding no reply
- Forwarding on busy/after timeout

Remark: The various forwarding types must be configured for the user.

The forwarding types are mutually exclusive except for "forwarding for internal" and "forwarding for external". You can program a forwarding destination for each of the two exceptions and activate them both.

Example:

You have activated variable forwarding. If you now program and thus activate forwarding after timeout, variable forwarding will be automatically deactivated and its forwarding destination will be deleted.

Selecting a variable forwarding type

Select Destinations and Forwarding in the Service menu.

Open the system menu.

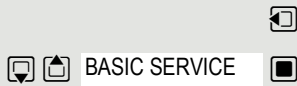

Select and confirm the basic service.



Select the menu item and confirm.



Confirm the option shown.
Variable forwarding is offered first.

FWD-VAR-ALL

Output on first line.

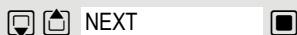

Confirm to select the next forwarding type.

FWD-FIXED off

Output on first line.

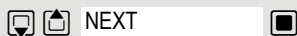

Confirm to select the next forwarding type.

FWD-VAR-ALL-INT

Output on first line.



Confirm to select the next variable forwarding type.

FWD-VAR-ALL

Output on first line.



Confirm to select the next variable forwarding type.

or



To edit the current variable forwarding type, select the required command.

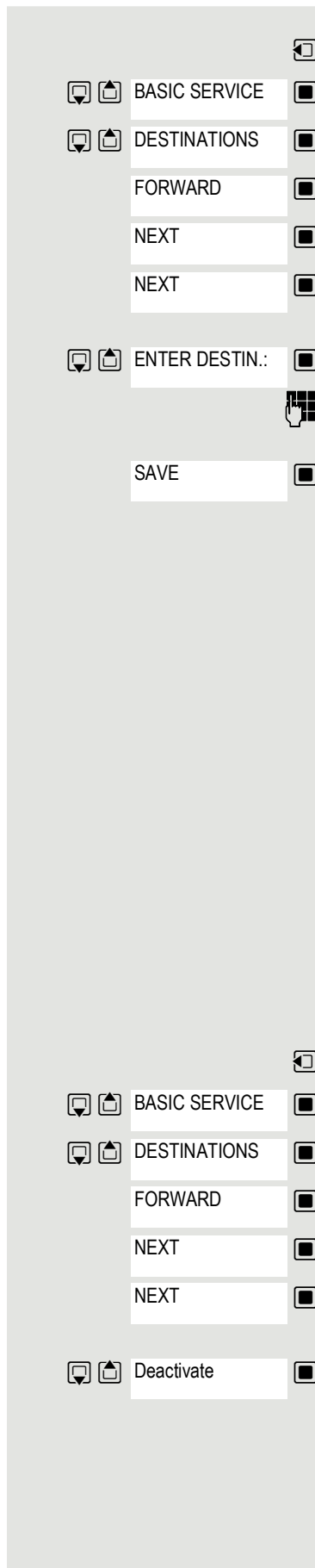

Programming a forwarding destination

Open the System Menu.

Select and confirm the basic service.

Select the menu item and confirm.

Confirm the option shown. "Variable forwarding" is displayed.

Confirm the option shown. "Fixed forwarding" is displayed.

Confirm the option shown. The display shows "Forwarding for internal".

Select and confirm the option shown.

Enter the phone number for the forwarding destination. Any destination previously programmed will be overwritten.

Confirm when the complete number has been entered.

To select a different forwarding type, proceed as described on → page 76.

If variable forwarding was previously programmed and activated, it is deactivated and the forwarding destination is deleted (for exception, see → page 76). Fixed forwarding is deactivated.

Deleting a forwarding destination

A variable forwarding destination is automatically deleted when the forwarding type is deactivated.

Activating variable forwarding

Variable forwarding is automatically activated when the forwarding destination is programmed.

Deactivating variable forwarding

You can deactivate all variable forwarding types in the Service menu (Basic Service).

Open the system menu.

Select and confirm the basic service.

Select the menu item and confirm.

Confirm the option shown. "Variable forwarding" is displayed.

Confirm the option shown. "Fixed forwarding" is displayed.

Confirm the option shown. The display shows "Forwarding for internal".

Select and confirm the option shown. Variable forwarding is deactivated and the forwarding destination is deleted.

To select a different variable forwarding type, proceed as described on → page 76.

Checking forwarding

To check the status of the forwarding types, proceed as described on → page 76. The forwarding destination is shown in the second line if this variable forwarding type is activated.

Activating and deactivating forwarding by means of an option

If a forwarding destination has been programmed for fixed forwarding, you can use the option to activate and deactivate the forwarding facility. If variable forwarding is activated, it can only be deactivated with this option.

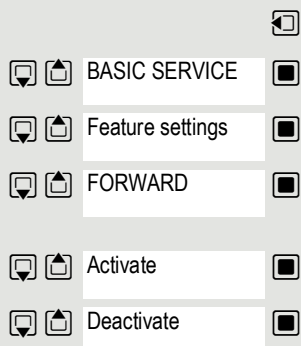

Open the system menu.

Select and confirm the basic service.

Select and confirm the option shown.

Select and confirm the option shown.

Select the menu item and confirm. The call forwarding function is activated.

Select the menu item and confirm. Call forwarding is deactivated. This deletes any destination number programmed for variable forwarding.

Forwarding calls automatically

Forwarding of internal and external calls in the system can be configured and activated for your line by your administrator. Calls can be forwarded:

- unconditionally
- when the line is busy
- when the call is not answered

Unconditional call forwarding should only be used if the line is for outgoing calls only (for example in an elevator).

If you have set up fixed or variable forwarding and if the manually programmed forwarding destinations are not obtainable (for example because they are busy), then calls are automatically forwarded to the system forwarding destinations.

Call forwarding with codes

Note:

The codes are dependent on the configuration in your communication system. Please consult your administrator.

You can use codes to set up the following forwarding types:

Forwarding type	Code (Example)
Program and activate fixed forwarding	* Δ 51
Activate fixed forwarding	* Δ 41
Delete (and deactivate) fixed forwarding	# ↵ 51
Deactivate fixed forwarding	# ↵ 41
Program and activate unconditional variable forwarding	* Δ 42
Program and activate variable forwarding for internal calls	* Δ 44
Program and activate variable forwarding for external calls	* Δ 43
Program and activate variable forwarding on busy	* Δ 45
Program and activate variable forwarding after timeout	* Δ 46
Program and activate variable forwarding on busy / after time-out	* Δ 47
Deactivate variable and fixed forwarding	# ↵ 41
Deactivate variable forwarding for internal calls	# ↵ 44
Deactivate variable forwarding for external calls	# ↵ 43
Activate system call forwarding	* Δ 90
Deactivate system call forwarding	# ↵ 90

The display messages for activating and deactivating call forwarding can be found on → page 73.

Programming and activating call forwarding



Hold down the Talk key.



Enter the code, for example *51 (ask your administrator). You will hear the dial tone.



Enter the destination number.



Enter the termination character. You will hear a confirmation beep and call forwarding is activated.



Press the End call key.

Activating fixed forwarding



Hold down the Talk key.



Enter the code, for example *41 (ask your administrator). You hear a confirmation tone.



Press the End call key.

Deactivating call forwarding



Hold down the Talk key.



Enter the code, for example #41 (ask your administrator). You hear a confirmation tone.



Press the End call key.

Canceling fixed forwarding



Hold down the Talk key.



Enter the code, for example #51 (ask your administrator). You will hear a confirmation beep and call forwarding is canceled.



Press the End call key.

Delayed call forwarding



Note:

This is configured for the entire system by your administrator.

Prerequisite: The second call function must be activated → page 68.

















If "Forwarding on busy / after timeout" or "Forwarding after timeout" is activated on your handset → page 76 and a second call comes in, you will automatically hear the call waiting tone and see the details of the caller on the display. You then have the option of accepting this call before call forwarding is activated (you may be urgently awaiting this call for instance).

The caller hears the ringing tone and is not forwarded to another extension until after a certain timeout.

Forwarding calls for a different terminal

You can save, activate, check and deactivate call forwarding for another telephone, fax machine or PC from your own handset. To do so, you need to know the PIN for the other station or have the "Call forwarding for other stations" class of service. Your administrator can help you in both cases.

Storing a destination for another telephone/activating call forwarding

- | | | |
|---|---|--|
|  | | Open the system menu. |
|   | BASIC SERVICE |  Select and confirm the basic service. |
|   | Feature settings |  Select the menu item and confirm. |
|   | FORWARD NUM- |  Select the menu item and confirm. |
| | VARY FORWARD |  Confirm the option shown. |
| |  | Enter the number of the other telephone. |
| | FINISHED? |  Confirm the option shown. |
| |  | Enter the PIN
(only if your own station does not have the "Call forwarding for remote terminal" class of service). |
| | FINISHED? |  Confirm the option shown. |
| |  | Enter the destination number. |
| | SAVE |  Confirm the option shown.
Call forwarding is activated immediately. |

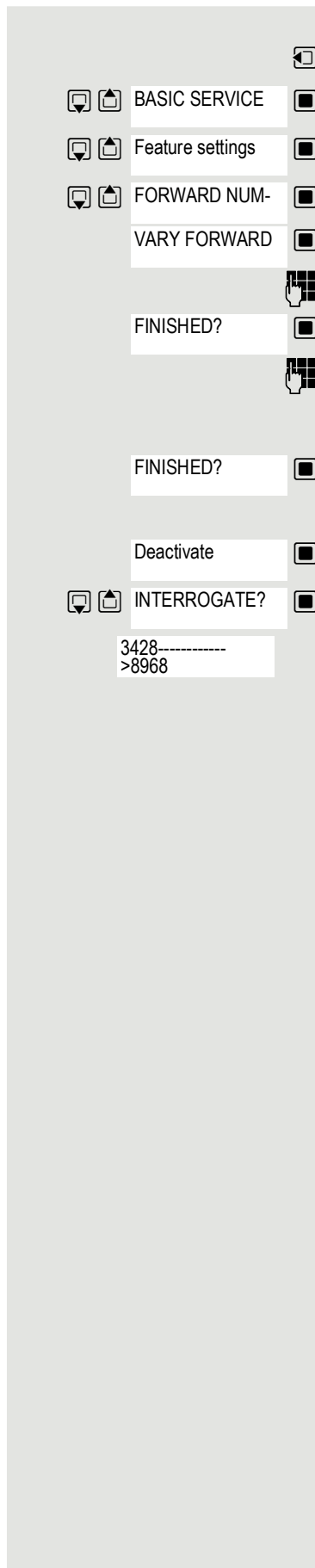

Deactivating/checking call forwarding for another telephone

Open the system menu.

Select and confirm the basic service.

Select the menu item and confirm.

Select the menu item and confirm.

Confirm the option shown.

Enter the number of the other telephone.

Confirm the option shown.

Enter the PIN

(only if your own station does not have the "Call forwarding for remote terminal" class of service).

Confirm the option shown.

Deactivating or checking:

Confirm or:

Select the menu item and confirm.

Sample display: Calls for station 3428 are redirected to station 8968.

Changing call forwarding for a different terminal

Proceed in the same way as for saving/activating: → page 81.

Mailbox

Callers who have tried to reach you during your absence can leave a callback request in your mailbox.

In the mailbox you will also find voice or fax messages from the mail server (if this has been set up).

Viewing the mailbox/selecting a mailbox entry

An advisory message appears and the message key flashes when one or more information messages or voicemails have been received for you.

Open the system menu.

Select the menu item and confirm.

The first entry is displayed on the screen.

Press to display the menu selection.

Select the menu item and confirm to select the next callback request.

Making a requested callback

The callback request is displayed.

Press to display the menu selection.

Select and confirm the option below.
The station will be called.

Deleting mailbox entries

Select the required entry → page 83.

The required entry appears.

Press to display the menu selection.

Select and confirm to delete the entry.

Note:

You cannot delete (new) voice messages that you have not yet listened to in full. To mark a message as "listened to", jump to the end of the message by pressing 66 for example (depends on the system). Callback requests must also be deleted from the missed calls list → page 69.

Ending mailbox viewing

Press to display the menu selection.

Select and confirm the option shown. Mailbox entries that have not been deleted remain saved.

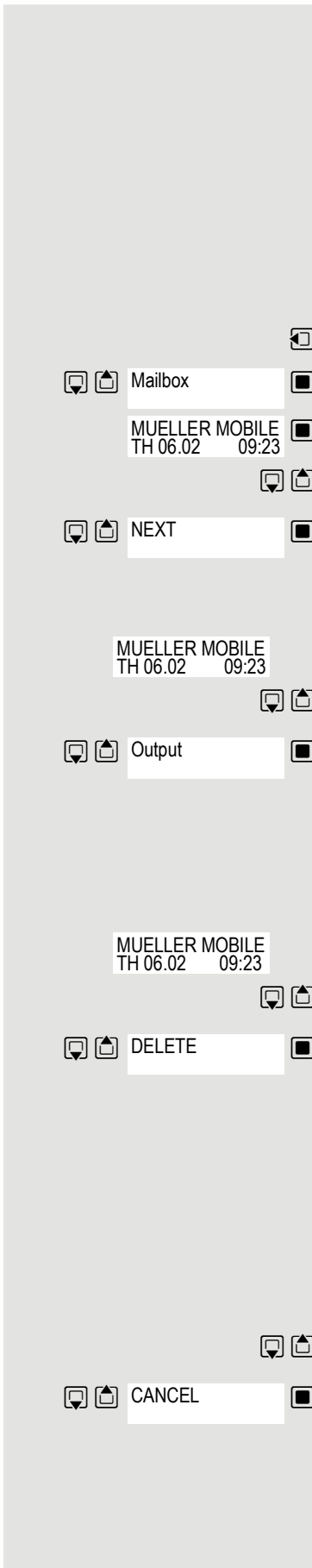

Using the OpenScape Xpressions mailbox function (optional)

Users with a mailbox (OpenScape Xpressions) can dial the messaging phone number to use this system's features and thus configure call forwarding types or listen to available messages. User voice prompts explain how to obtain all the available functions. If call forwarding to the mailbox is activated, the messaging phone number is shown on the display → page 73.

More features

Making calls using project assignment (cost billing)

You can assign external calls to certain projects.

Prerequisite: Project numbers (from 1 to 5) have been configured for certain projects and you have an account code (ACCT) for the project.



Note:

The function must be approved for your communications system.



Open the system menu.



BASIC SERVICE



Select and confirm the basic service.

Either:



Enter a service code between 61 (for project number 1) and 65 (for project number 5).



Enter the PIN

Or:



PIN / COS?



Select the menu item and confirm.



PIN 1?



Select the required PIN and confirm.

...

Then:



Enter the external phone number.
Then make your phone call as usual → page 14.



A time limit is applied to project assignment. It is automatically deactivated if you have not used your handset for a period of more than five minutes, for instance.

Callback

This function enables you to call a user who does not answer or whose line is busy. The Callback function enables you to contact this user as soon as he or she hangs up or re-uses his or her telephone. Please note that a line is signaled as busy when it is being called by another user. You can continue to use your handset without restriction when a callback has been booked.

Booking a callback

The number is dialed. You hear the busy tone or the user does not answer.

Save the callback request.

Press the End call key to end the operation.

You receive a callback

You are then called back:

- as soon as the selected user terminates his or her call, or
- the first time the user uses his or her handset¹, or

as soon as the other party checks his or her mailbox and responds to your callback request¹ → page 86.

Press the Talk key briefly. The connection is set up.



Note:

Callbacks are repeated until a connection is established or until the callback is deleted. A handset can initiate up to five callbacks and can be the destination for up to five callback requests. If these conditions are met, any further callbacks are rejected.

Deleting a callback request

Open the system menu.

Select the menu item and confirm.

The oldest entry is displayed first.

Select the required command.

Displaying the next entry:

Select and confirm the command to view the next entry.

Deleting an entry that is displayed:

Select and confirm the command.

You receive confirmation: "Callback deleted".

Terminating callback display:

Select and confirm the command.

Press the End call key to end the operation.

CALLBACK



Callback



MUELLER MOBILE
TH 06.02 09:23



Next



DELETE



Callback deleted



CANCEL



Using a different telephone in the same way as your own

You can log on to another telephone belonging to the HiPath 4000 system using a personal identification number (PIN). This also applies to telephones in networked HiPath 4000 systems, for example at other company locations. At the other telephone you can then

- make calls and assign the charges to cost centers,
- make calls and assign the charges to specific projects,
- check your mailbox,
- enter appointments.

Using an internal PIN, you can have your calls diverted to a telephone in the office or department where you will be for a temporary period (call forwarding - "follow me").



Note:

The function must be approved for your communications system.

Prerequisite: You have been assigned a PIN by your administrator. You require an internal PIN for calls within your own HiPath 4000 system, while for calls involving other HiPath 4000 systems in the integrated network you require a network-wide PIN.

Open the system menu.

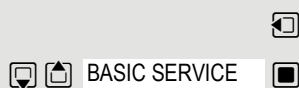

Select and confirm the basic service.

Either:



Enter the service code
(61 for PIN 1, 62 for PIN 2, etc.).

Or:



Select the menu item and confirm.

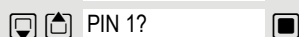

Select the menu item and confirm.
If you have several PINs and wish to use another one, select the other PIN.

then:

You are prompted to enter the PIN by the message "Enter station no." or "Enter ID" on the display.

The following applies within your own HiPath 4000 system:



Enter your internal PIN.

The following applies within your own and another system within the integrated network HiPath 4000:



Enter the 2-digit node ID of your own HiPath 4000 system (consult your administrator).



Enter your own number and press the hash key.



Enter the network-wide PIN and press the hash key.

Dialing after (successful) identification:

You will hear the dial tone. The following appears on the display: "Please dial"



Enter a phone number.

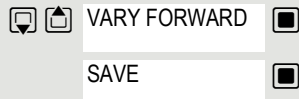

Call forwarding - follow me after successful identification:

Select the menu item and confirm.

Confirm the option shown. Call forwarding is activated immediately.

Caller ID suppression

The caller ID display can only be suppressed for one subsequent call and the setting is not saved if the number is redialed.



Note:

The function must be approved for your communications system.

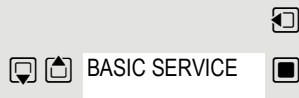

Either:



Open the system menu.

Select and confirm the basic service.

Enter the service code.

Or:

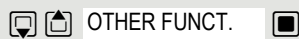

Select the menu item and confirm.



Select the menu item and confirm.

then:



Enter the phone number of the user. If the called party accepts the call, your phone number will not be displayed.

Activating/deactivating do not disturb

If you do not wish to take calls, you can activate do not disturb. Internal callers will hear the ringing tone and the announcement "Do Not Disturb"; external calls will be diverted to the attendant. Your administrator can also set up call forwarding destinations for the "Do not disturb" function, to which you can forward your internal and external calls.

Prerequisite: The administrator has enabled the Do Not Disturb function for all extensions.

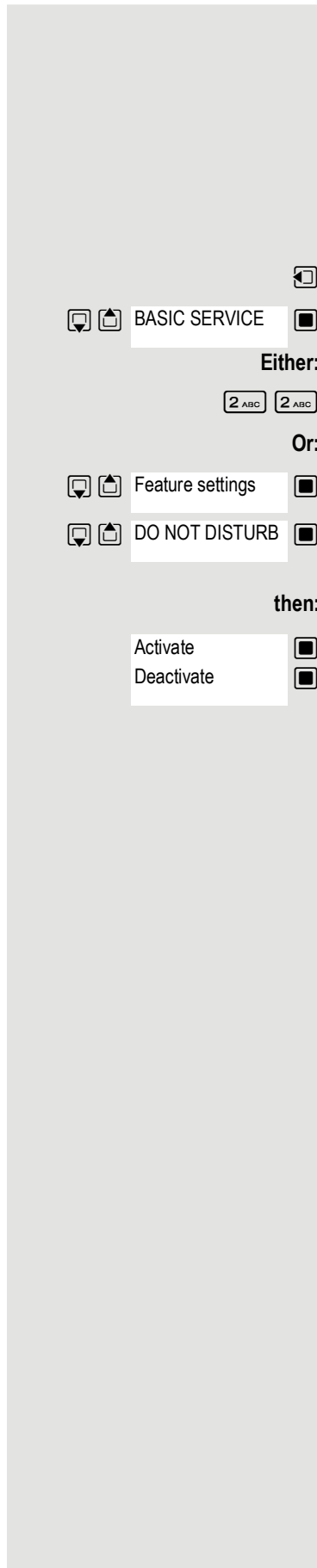

Open the system menu.

Select and confirm the basic service.

Either:

2 ABC 2 ABC

Enter the service code.

Or:

Feature settings

Select the menu item and confirm.

DO NOT DISTURB

Select the menu item and confirm. The display indicates whether "Do not disturb" is activated or not.

then:

Activate

Confirm the display if "Do Not Disturb" should be activated.

Deactivate

Confirm the display if "Do Not Disturb" should be deactivated.



Note:

A tone reminds you that Do Not Disturb is activated when you seize the trunk.

The attendant can circumvent the Do Not Disturb function and reach you anyway.

If the administrator has locked the Do Not Disturb function for all users, the item "Do Not Disturb" will not appear in the Service menu.

Tracing a call

You can identify malicious external callers. You can record the caller's phone number during a call or for up to 30 seconds after a call. You should not hang up in the process.



Note:

The function must be approved for your communications system.

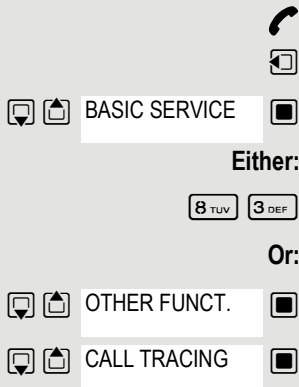

During the call.

Open the system menu.

Select and confirm the basic service.

Either:

8 TUV 3 DEF

Enter the service code.

Or:

OTHER FUNCT.

Select the menu item and confirm.

CALL TRACING

Select the menu item and confirm.



Note:

If the trace is successful, the transmitted data is stored by your network operator. Consult your administrator.

Entering commands via tone dialing (DTMF suffix dialing)

After dialing a phone number, you can activate DTMF tone dialing (dual-tone multifrequency signaling) in order to operate devices, such as answering machines or automatic directory inquiry or switching systems, by means of command inputs.

You are connected.

Open the system menu.

  BASIC SERVICE 



Select and confirm the basic service.

Either:

Enter the service code.

Or:

  OTHER FUNCT. 

Select the menu item and confirm.

  DTMF DIALING 

Select the menu item and confirm.

You can now enter commands with the keys 0 to 9, the star key and the hash key.

 **Note:**

Ending the call also deactivates DTMF suffix dialing.

Depending on the system configuration, "DTMF DIALING" may be displayed immediately after the number has been entered. In this case, you can enter commands immediately after dialing a phone number.

Parking/activating calls

You can park up to 10 internal and/or external calls and resume them at another telephone.

Calls cannot be parked if:

- All parking positions are busy.
- The parking position you have selected is busy.
- The user is the attendant console.
- The call is a consultation call.
- The call is part of a conference.

Parking and resuming a call

You can park a call to your handset in a free parking position and resume it on your own telephone or on another one. This function can also be performed on telephones that do not have a display.

You are conducting a call.



Enter the system parking code (consult your administrator if you need assistance).

1 ... 9

Enter and note a parking position number between 1 and 9. The call is parked.



Press the End call key.

Retrieving a parked call



The handset is not in the charging cradle. Hold down the Talk key.



Enter the system parking code (consult your administrator if you need assistance).

1 ... 9

Enter the parking position number between 1 and 9 that you have noted and continue your call.

Parking is not possible

If the selected parking position or all parking positions are busy or if call parking is not available for some other reason, you will receive both an acoustic and a visual message.

If the selected parking position is occupied, you will receive a display message and hear the busy tone.

Either:

TO WAIT. CALL



Confirm and continue the call.

Or:



Press the End call key. You receive a recall for the call on hold.

System-wide speaker call

You can place a speaker call to an internal party on HiPath 4000 using the loudspeaker on their telephone to establish a connection. You can also initiate a speaker call from a consultation call.

To cancel a speaker call, replace the handset or - during an inquiry - resume the call that was in progress.



Note:

Please ensure for all functions that "Speaker call protect" is deactivated on the relevant phones → page 94.

If a speaker call is placed to a party and "Speaker call protect" is activated, the speaker call will be ignored and a normal call will be placed.



Privacy:

You can place a speaker call to a called subscriber but will not hear the other party unless they have pressed the Talk key.

From your handset, you can directly call any internal user whose telephone has the speakerphone function or a loudspeaker.

A destination party is contacted via his or her internal phone number.

Speaker call



The handset is not in the charging cradle. Press and hold down the Talk key.



Enter the code for "Speaker call" and



the user's phone number.

A connection to that user's loudspeaker will immediately be established if:

- the station is not busy,
- the handset has not been lifted and
- speaker call protect is not activated.

The caller hears a confirmation tone when the connection has been established and can start speaking.

The called party can accept the call by lifting the handset.



Note:

The number of possible speaker calls and normal calls is the same.

Activating/deactivating "Speaker call protect"

You can protect yourself against being addressed directly with a speaker call. Attempts to address you directly over the speakerphone will then become normal calls.

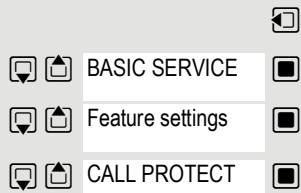

Open the system menu.

Select and confirm the basic service.

Select the menu item and confirm.

Select the menu item and confirm.

Weiter:

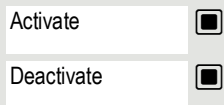

Activating or deactivating

Confirm the menu item displayed.

System appointment function

You can arrange for the communications system to remind you of an appointment. For this to happen, you need to save the times at which you wish to be reminded. This is possible for a period of up to 24 hours in advance.

Saving an appointment

Open the system menu.

Select and confirm the basic service.

Either:

7 PQRS

Enter the service code.

Or:

Select and confirm the option shown.

The display indicates whether an appointment reminder has already been saved.

Select the menu item and confirm.

then:



Enter the time as 3 or 4 digits, for example 845 for 8.45a.m. or 1500 for 3p.m.

SAVE

Confirm the option shown.

Deleting a saved appointment

Open the System Menu.

Select and confirm the basic service.

Either:

7 PQRS

Enter the service code.

Or:

Select and confirm the option shown. A saved reminder is displayed.

Confirm if you have saved several reminders.

then:

DELETE

Select the menu item and confirm.

Press the End call key.

Using timed reminders

Prerequisite: You have saved a reminder. The saved time arrives.

The handset starts ringing.

Press the Talk key. The appointment time is displayed.

Press the End call key.

 If you do not accept the reminder, the handset will ring a few more times and "Appoint." will be displayed before the reminder is deleted.

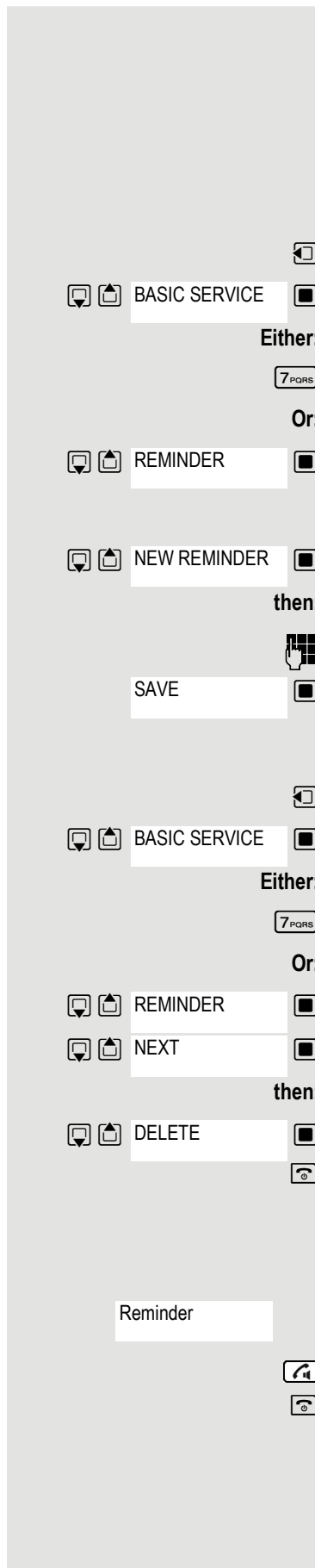

Locking the telephone line to prevent misuse

You can prevent unauthorized persons from using your telephone (and the system directory) during your absence.

Prerequisite: You have been assigned a personal identification number (PIN) by the administrator responsible for your communications system.





Note:

As an alternative, however, you can lock your handset against misuse (see local functions). Neither of these two locks may be active if you want to place a call. The PINs for locking the telephone line and for the handset are not identical.

Locking the telephone line to prevent unauthorized dialing

Open the system menu.

  BASIC SERVICE 

Select and confirm the basic service.

Either:

Enter the service code.

Or:

  PIN / COS? 

Select the menu item and confirm.

  CHANGE COS 

Select the menu item and confirm.

then:



Enter the PIN (code no.).



Press this key. If the PIN is correct, it will be confirmed with: "carried out" on the display.

Enabling the telephone again:

Open the system menu.

  BASIC SERVICE 

Select and confirm the basic service.

Either:

Enter the service code.

Or:

  PIN / COS? 

Select the menu item and confirm.

  CHANGE COS 

Select the menu item and confirm.

then:



Enter the PIN (code no.).



Press this key. If the PIN is correct, it will be confirmed with: "carried out" on the display.

Index

A

Advisory tones	44
Alarm	33
Alarm clock	32
switch on/off	32
Alert tone (beep)	30, 43
Anniversary, see Appointment	
Answer machine	
calling back a caller	21
Answer, auto	44
Answering machine, play messages	28
Appointment	
display missed	31
missed	31
notification	30
saving	95
setting	30
Appointments	
~in system	95
confirming	95
deactivating	95
Assigning number key	45
Authorisation	48
Auto answer	44
Automatic	
redial	19

B

Battery	
charging	11
inserting	11
Beacon	38
Beep (alert tone)	30, 43
Belt clip	12
Bluetooth	36
activate	36
beacon	38
changing the device name	38
copy directory (vCard)	25
copying directory	25
de-register devices	37
list of known devices	37
making a device visible/invisible	36
registering devices	37
Broken display	8

C

Calendar	30
Call	
anonymous~	88
external	18
holding	59
incoming	19
parking	92

Transferring	62
Call charge assignment	85
Call forwarding	73
Forwarding calls for a different terminal	82
Call list	
copying a number to the directory	21
delete	21
delete an entry	21
dialling	19
entry	21
opening	21
Call lists	21
Call number	
suppression	88
Call protection	33
Call, anonymous	
protection from	33
Callback	86
Callback request	83
Caller list	69
Calls	
making an external call	18
Care	49
Care of the device	49
Changing	
display language	39
Changing the device name (Bluetooth)	38
Changing the handset PIN	46
Character charts	51
Charging cradle (handset)	
connecting	10
Charging time of handset	50
CLIP image	
view in resource directory	35
CLIP-picture, in directory	24
Colour scheme	40
Conference	
adding a party	67
initiating	67
transferring	67
Connecting the USB data cable	13
Consultation	59
Consultation (second connection)	59
Contact	
sending from smartphone	25
Contact with liquid	49
Contents of the package	10
Control key	6, 14
Copying	
all	71
entry	71
Copying all	71
Copying entry	71
Copying the directory	71
Correcting incorrect entries	17
Countdown (timer)	32

Country	39	Entering special characters.....	17
Customer Care	48	Entering text	17
Customer Service	48	Entering umlauts	17
<hr/>			
D			
Delayed call forwarding	81	F	
DELETE	86	Feature key	40
De-registering devices (Bluetooth)	37	Forwarding	
Dialling		variable	76
from the call list	19	Functions	58
from the redial list	18	<hr/>	
using quick dial	45	G	
Different telephone	86, 87	Getting started	10
Directories		<hr/>	
using them	23	H	
Directory	23	Handset	
copy vCard (Bluetooth)	25	automatic keypad lock	41
copying numbers	25	changing the settings	39
entry	23	colour scheme	40
memory	24	connecting the charging cradle	10
open	23	display backlight	40
order of entries	24	display language	39
saving an entry	23	handset volume	20
searching	24	handsfree volume	20
selecting an entry	24	idle status	16
sending with Bluetooth	25	keypad illumination	41
Directory key		muting	20
assignment	23	overview	6
Directory, copying	71	registering	12
Display		resetting	47
backlight	40	restoring to default setting	47
broken	8	set up	11
changing display language	39	switch on/off	14
colour scheme	40	using as a Bluetooth beacon	38
directory memory	24	Handsfree key	19
large font	39	Handsfree mode	19
missed appointment/anniversary	31	Handsfree profile	42
network mailbox message	22	Handsfree volume	20
screensaver	39	Hash key	6
setting	39	Headset (Bluetooth)	36
Display icons	54	Headset connection	6
Display keys	6, 15	Headset socket	13
assigning	45	Headset volume	42
icons	54	Help	48
Display language		Holding	59
setting	12	<hr/>	
Disposal	48	I	
"Do not disturb" profile	29	Icons	
Do not disturb	94	alarm clock	32
<hr/>			
E			
Earpiece profile	42	alarm icons	56
Earpiece volume	20	displaying new messages	22
automatic	42	indications	55
Emergency numbers	44	on display keys	54
not possible	8	status bar	54
End call key	6, 18	timer	32
Entering numbers	17	Identification number	87
<hr/>			
I			
Idle status			
returning to			
16			

Illumination, keypad	41
Indications, icons.....	55
Information message, Message, viewing	83
K	
Key 1 (fast access).....	6
Key, assigning	45
Keypad illumination	41
Keypad lock, automatic	41
Keys	
control key	6, 14
display keys.....	6, 15
end call key	6, 18
handsfree.....	19
hash key.....	6
menu	14
message key	6
on/off key	6
recall key	6
star key.....	6
talk key.....	6
L	
Language	
display.....	39
Large font	39
Liquid	49
List	
known devices (Bluetooth).....	37
Lock/unlock the keypad.....	14
Locking/unlocking system.....	96
Loud surroundings	20
Lower/upper case	17
M	
Mailbox	83, 84, 87
Mains unit	
handset.....	51
Making anonymous calls.....	88
Making calls	
external.....	18
Manufacturer's advice	48
Medical equipment	9
Melody	
ringtone for internal/external calls	43
Memory in the directory	24
Memory, resource directory	35
Menu key.....	14
Message key	6
Message lists	22
Messages	
play on network mailbox.....	28
Microphone	
adjust sensitivity.....	20, 42
switch on/off	20
volume	42
Missed anniversaries/appointments.....	31

Muting the handset	20
N	
Network mailbox.....	
enter number	28
play messages	28
Network MB, see Network mailbox	
Number	
copying to the directory.....	25
saving in the directory	23
O	
On/off key	6
Open Source Software.....	101
Operating time of handset	50
Override.....	61
Overview	
handset	6
P	
Parking a call	92
Picture	
as CLIP image.....	35
as screensaver	35
formats	35
Play sound.....	35
Power adapter	
handset	8, 51
handset	51
Project assignment	85
Protection from calls	
"Do not disturb" profile.....	29
anonymous.....	33
switch off ringtone when in charging	
cradle.....	34
time control.....	33
R	
Recall key	6
Redial list	18, 21
Registering (handset).....	12
Registering device (Bluetooth).....	37
Resource Directory	
memory	35
Resource directory	
view CLIP image.....	35
Ringtone.....	
automatic volume	42
changing	43
disable.....	19
melody for internal/external calls	43
switch off when in charging cradle	34
time control.....	33
volume.....	43
S	
Safety precautions.....	8
Screensaver	39

Searching in directory	24	Technical data	50
Second call	68	Telephone	
Second connection (consultation)	59	operating	14
Sensitivity		Time control for external calls	33
volume	42	Timer	32
Setting up		Tracing a call	90
handset	11	Transferring	62
Show new messages	22	Transferring a call	62
Signal strength	54	Transferring(call)	62
Snooze mode (alarm)	33		
Sound		<hr/>	
formats	35	U	
playback	35	Upper/lower case	17
Sounds for ringtones	35	USB connection socket	6
Speaker	19	<hr/>	
Speaker call	93	V	
Speaker calling	94	Variable Forwarding	76
Star key	6	Viewing network mailbox message	22
Status bar		VIP group, classify directory entry	24
icons	54	VIP ringtone	24
Switch on/off alarm (timer)	32	Volume	
Symbols, see Icons	54	earpiece	41
System functions	58	handset speaker/earpiece volume	20
		headset	41, 42
		speaker	41
<hr/>			
T			
Talk key	6		

All rights reserved. Rights of modification reserved.

Open Source Software

General

Your device includes Open Source software that is subject to various license conditions. With regard to Open Source software, the granting of usage rights that go beyond the operation of the device is governed by the relevant license conditions of the Open Source software. The corresponding licence conditions can be found below in their original version.

The respective license texts regularly contain limitations of liability with regard to the relevant licensor of Open Source Software. The exclusion of liability for the LGPL Version 2.1, for example, reads as follows:

„This library is distributed in the hope that it will be useful, but WITHOUT ANY WARRANTY; without even the implied warranty of MERCHANTABILITY or FITNESS FOR A PARTICULAR PURPOSE. See the GNU Lesser General Public License for more details.”

The liability remains unaffected by this.

Licence and copyright information

Your device includes Open Source software. The corresponding licence conditions can be found below in their original version.

Licence texts

Copyright (c) 2001, Dr Brian Gladman < >, Worcester, UK.

All rights reserved.

LICENSE TERMS

The free distribution and use of this software in both source and binary form is allowed (with or without changes) provided that:

1. distributions of this source code include the above copyright notice, this list of conditions and the following disclaimer;
2. distributions in binary form include the above copyright notice, this list of conditions and the following disclaimer in the documentation and/or other associated materials;
3. the copyright holder's name is not used to endorse products built using this software without specific written permission.

DISCLAIMER

This software is provided 'as is' with no explicit or implied warranties in respect of its properties, including, but not limited to, correctness and fitness for purpose.
